

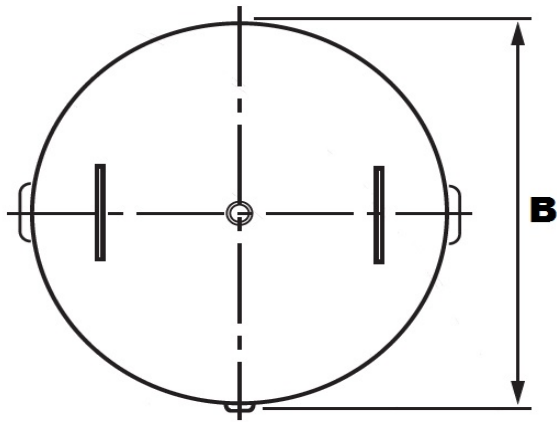

## Commercial Buffer Tanks Tank Model TSB80-B



TECHNICAL DATA	
<b>CAPACITY:</b>	80 Gallon
<b>EXTERIOR:</b>	Red Oxide Primer
<b>DESIGN PRESSURE:</b>	125 psi
<b>DESIGN BUILD:</b>	ASME Section VIII, Division 1 Carbon Steel
<b>WEIGHT:</b>	310 lbs

DIMENSIONS		
ID	DESCRIPITON	DIMENSION
A	Height, Overall	49"
B	Diameter	24"
C	Inlet / Outlet, Bottom Conn's	16-3/4"
D	Inlet / Outlet, Top Conn's	36-1/4"

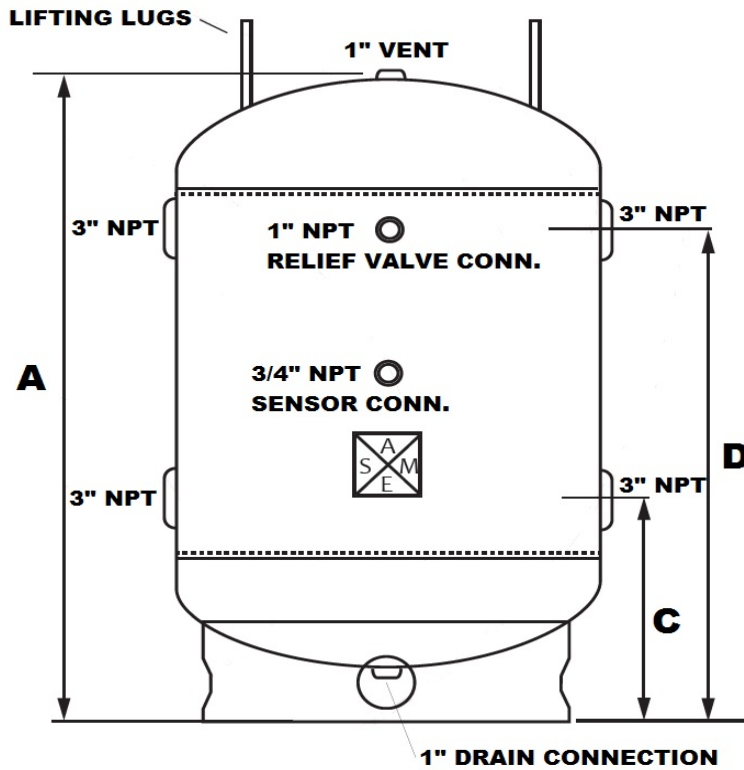

SUBMITTAL	
<b>JOB NAME:</b>	
<b>LOCATION:</b>	
<b>ENGINEER:</b>	
<b>WHOLESALE:</b>	
<b>CONTRACTOR:</b>	
<b>DATE:</b>	

Notes: