

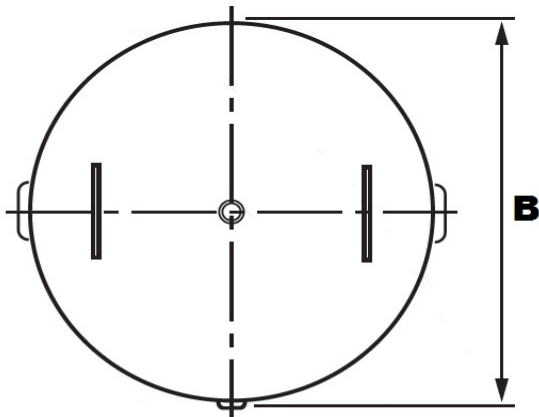

Commercial Buffer Tanks Tank Model TSB40-B



TECHNICAL DATA	
CAPACITY:	40 Gallon
EXTERIOR:	Red Oxide Primer
DESIGN PRESSURE:	125 psi
DESIGN BUILD:	ASME Section VIII, Division 1 Carbon Steel
WEIGHT:	185 lbs

DIMENSIONS		
ID	DESCRIPITON	DIMENSION
A	Height, Overall	45"
B	Diameter	18"
C	Inlet / Outlet, Bottom Conn's	14-1/4"
D	Inlet / Outlet, Top Conn's	33-3/4"

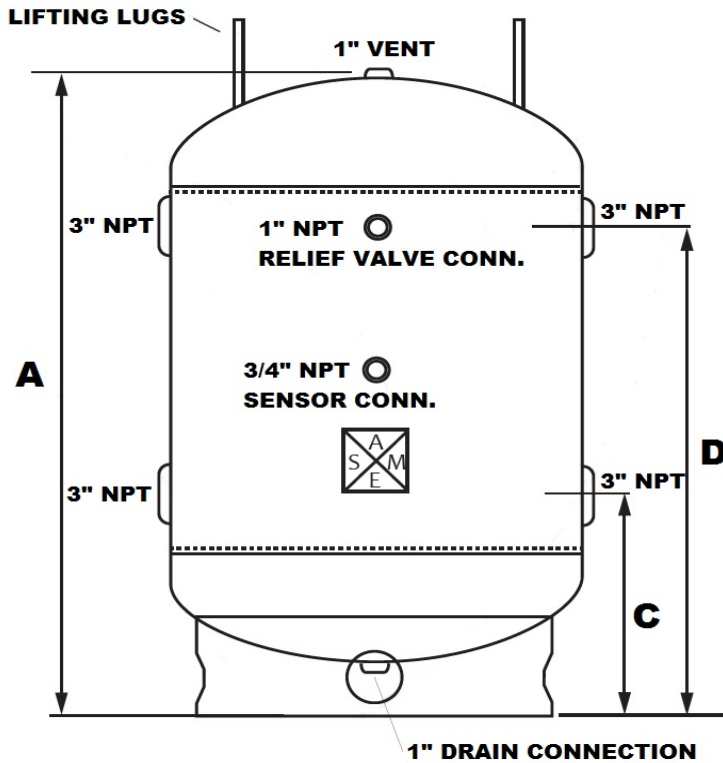

SUBMITTAL	
JOB NAME:	_____
LOCATION:	_____
ENGINEER:	_____
WHOLESALE:	_____
CONTRACTOR:	_____
DATE:	_____

- Notes:
- 1) Tank information is subject to change without notice.
 - 2) Standard tank configuration; job specific options available.