

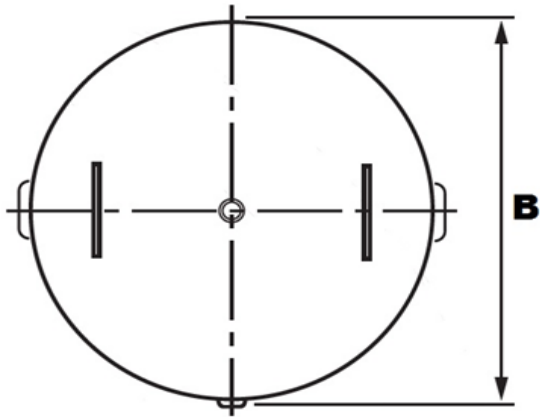

Commercial Buffer Tanks Tank Model TSB-285



TECHNICAL DATA	
CAPACITY:	285 Gallon
EXTERIOR:	Red Oxide Primer
DESIGN PRESSURE:	125 psi
DESIGN BUILD:	ASME Section VIII, Division 1 Carbon Steel
WEIGHT:	760 lbs

DIMENSIONS		
ID	DESCRIPITON	DIMENSION
A	Height, Overall	76"
B	Diameter	36"
C	Inlet / Outlet, Bottom Conn's	24-1/2"
D	Inlet / Outlet, Top Conn's	55-1/2"

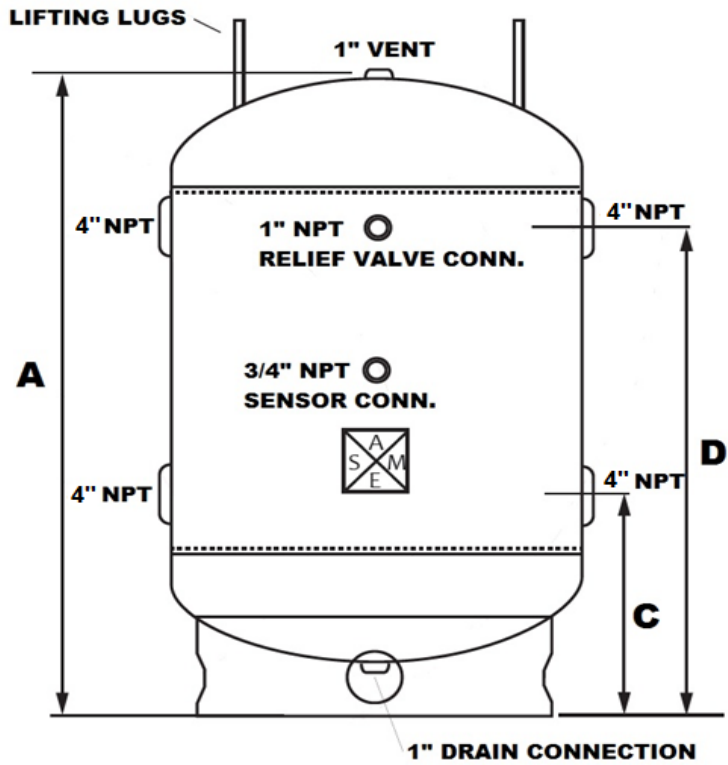

SUBMITTAL	
JOB NAME:
LOCATION:
ENGINEER:
WHOLESALER:
CONTRACTOR:
DATE:

- Notes:
- 1) Tank information is subject to change without notice.
 - 2) Standard tank configuration; job specific options available.