

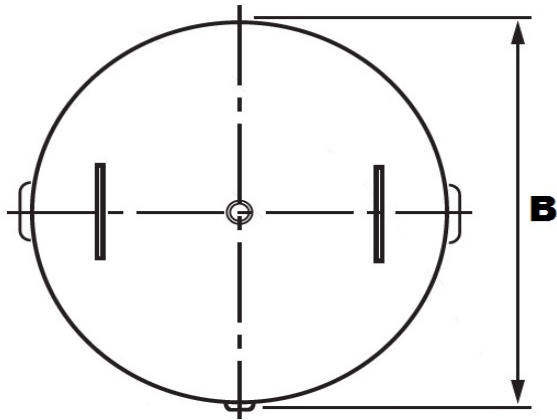

Commercial Buffer Tanks Tank Model TSB120-B



TECHNICAL DATA	
CAPACITY:	120 Gallon
EXTERIOR:	Red Oxide Primer
DESIGN PRESSURE:	125 psi
DESIGN BUILD:	ASME Section VIII, Division 1 Carbon Steel
WEIGHT:	310 lbs

DIMENSIONS		
ID	DESCRIPITON	DIMENSION
A	Height, Overall	49"
B	Diameter	30"
C	Inlet / Outlet, Bottom Conn's	16-3/4"
D	Inlet / Outlet, Top Conn's	36-1/4"

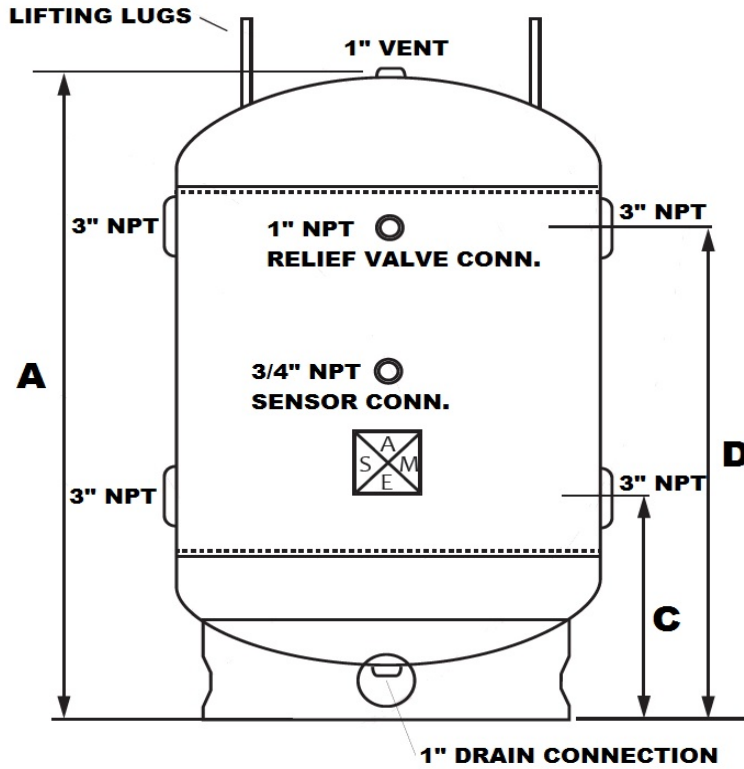

SUBMITTAL	
JOB NAME:	
LOCATION:	
ENGINEER:	
WHOLESALE:	
CONTRACTOR:	
DATE:	

- Notes:
- 1) Tank information is subject to change without notice.
 - 2) Standard tank configuration; job specific options available.