



SPIROVENT QUAD®



Air Eliminator
Dirt Separator
Low Loss Header
Hydraulic Separator



SPIROTHERM

The Ultimate in Distribution Efficiency

Air- and dirt-free system water through a single unit, plus hydraulic separation in a low loss header.

The life and efficiency of a heating or cooling system are greatly dependent on the quality of the system water. Air and dirt problems cause frequent breakdowns and increased customer complaints. Corrosion, cavitation, and component wear are consequences of dirty, air-saturated water. Recurring problems and increased maintenance result in unnecessary costs and dissatisfied owners.

Many systems now have the need for hydraulic balance due to separate circuits with variable speed pumps or the need for chiller and boiler loops. Combining all these features in a low loss header saves time and reduces installation costs.

There is a solution!

A hydraulically balanced system without air and dirt is possible. There is a unique four-purpose device that will remove air and dirt to keep the system clean and function as a hydraulic separator in a low loss header.

It includes connections for two separate circuits, requires little maintenance, and works without strainers or filters. Less maintenance, fewer costs, satisfied owners!

The name:

SPIROVENT QUAD

Quad Brass
1"-2"
Threaded,
Sweat or
Press Fit



Quad Steel
2"-12"
Threaded or Flanged
ASME through 4"
Flanged
ASME 5"-12"



The Key Difference

Unlike other products which are empty vessels or include only a baffle plate, the Spirovent Quad® combines the features and benefits of the industry-leading Spirovent® air eliminator along with the Spirotrap® dirt separator.

The coalescing element and dirt separation medium completely fill the internal volume of the vessel, providing unsurpassed efficiency. Connections have been engineered and placed to allow for the ultimate in hydraulic balance.

The unique construction of this combined unit allows for the removal of both entrained air and dirt particles. The patented Spirotube®, the core of the Spirovent Quad, creates a low velocity area in the Spirovent core that allows removal of 100% of the free air, 100% of the entrained air, and up to 99.6% of the dissolved air in the upper chamber. The lower chamber allows the dirt particles to sink with 80% of those 30 microns and larger removed within 100 passes. Dirt and sediment sink to the bottom of the unit and collect in the dirt chamber, eliminating any blockage concerns. The dirt can be flushed through the drain while the system remains fully operational, and the large collection chamber ensures infrequent flushing.

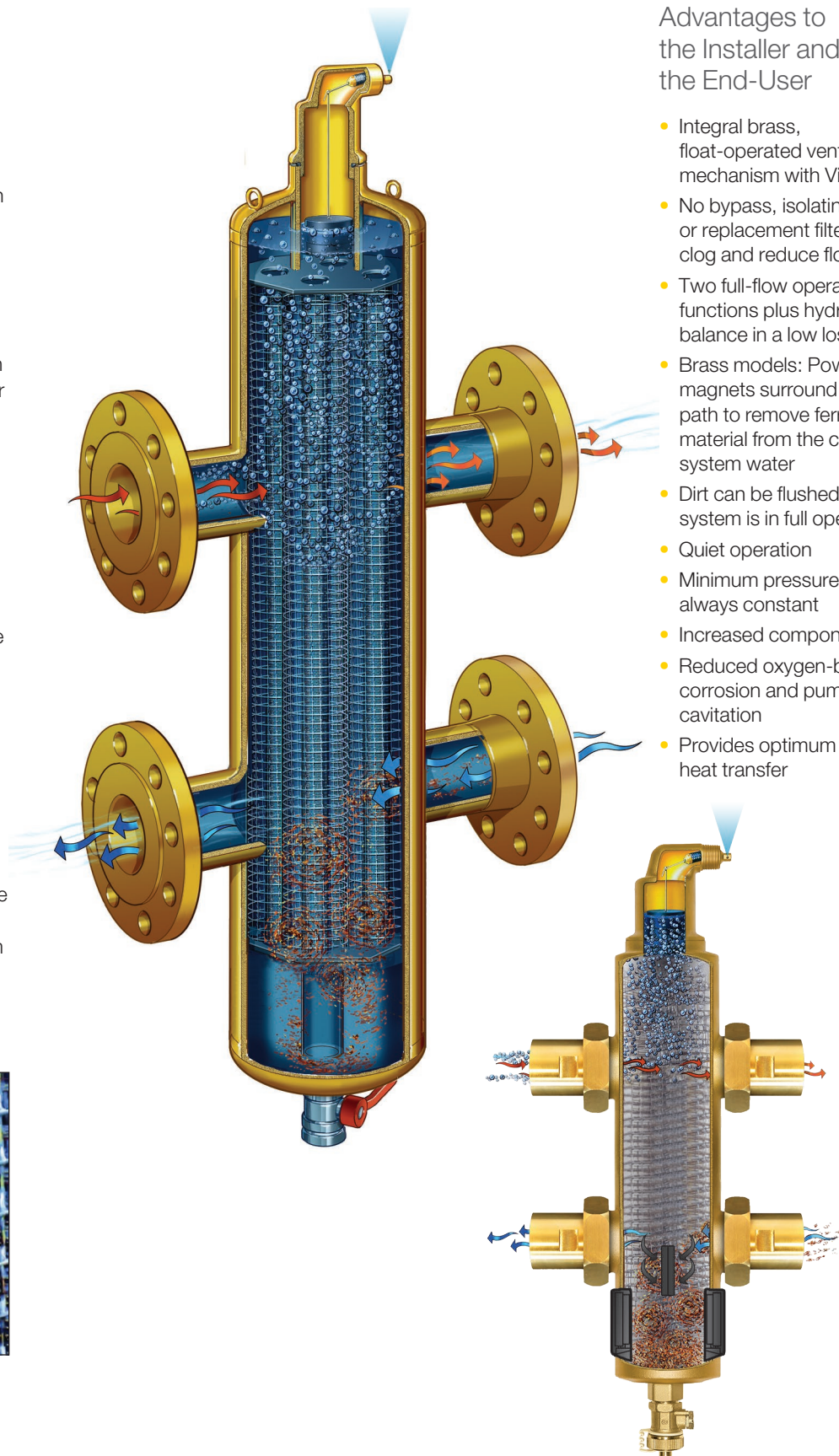
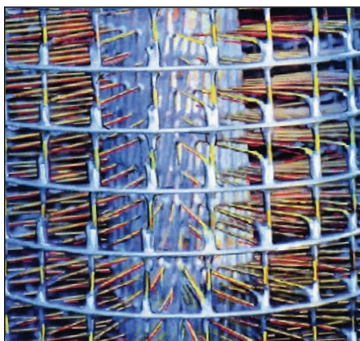

Advantages to the Installer and the End-User

- Integral brass, float-operated venting mechanism with Viton® seal
- No bypass, isolating valves or replacement filters to clog and reduce flow
- Two full-flow operating functions plus hydraulic balance in a low loss header
- Brass models: Powerful magnets surround the flow path to remove ferrous material from the circulating system water
- Dirt can be flushed while the system is in full operation.
- Quiet operation
- Minimum pressure drop; always constant
- Increased component life
- Reduced oxygen-based corrosion and pump cavitation
- Provides optimum heat transfer

Primary/Secondary Piping...done right.

Quad Advantages

- Spirovent's unrivaled air elimination and dirt separation efficiency is at the heart of every Quad.
- 20-year warranty on brass models, 3-year warranty on steel models.
- Factory-installed integral, serviceable air vent
- Blow down valve included with every Quad.
- Gasketed union tailpiece on all brass units.
- All models designed as standard for 150 psig and 270° F. Higher pressures/temperatures available.
- Brass models 1"-1½" include powerful magnet

Pressure Drop

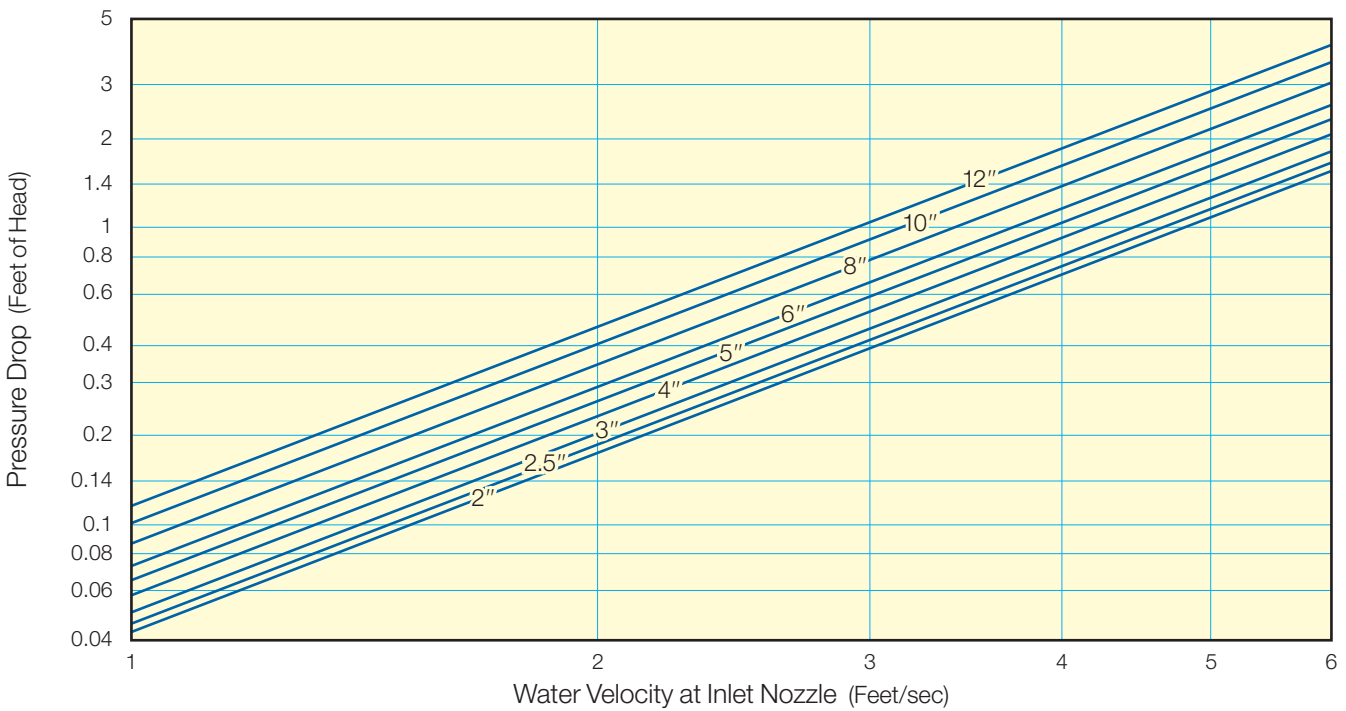

At rated flows pressure drop for 1" to 2" brass models is 0.50 feet.

Dirt Separation Efficiency

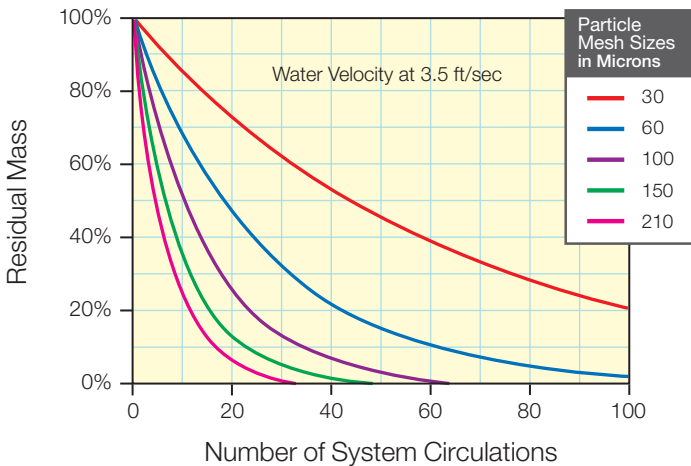

Spirovent Quad

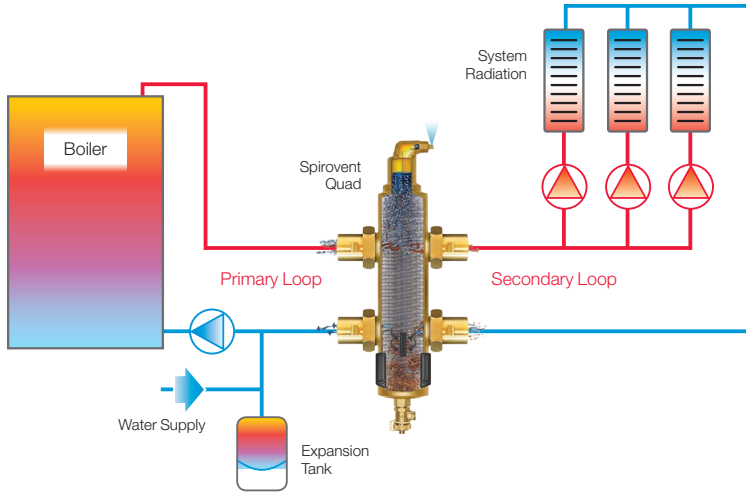

Spirovent Senior Quad: Two Boilers

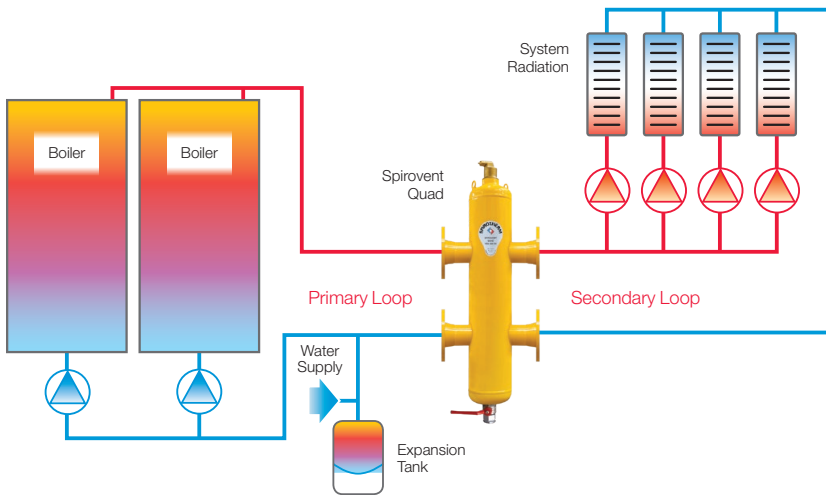

Spirovent Senior Quad: Chilled Water System

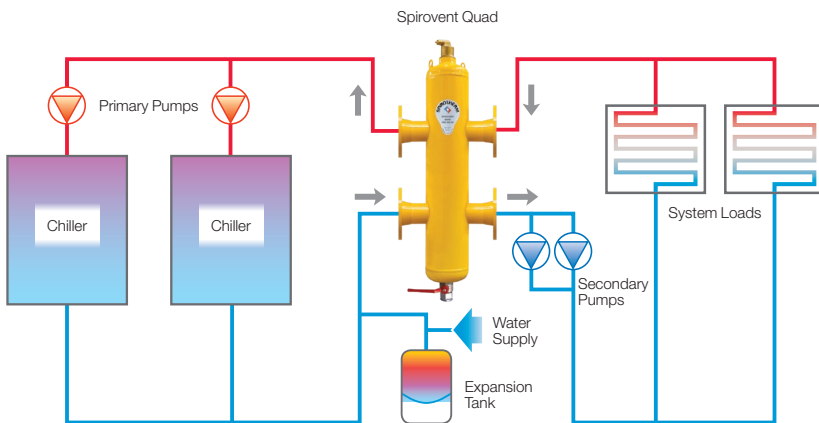

How exactly does a hydraulic separator work?

A hydraulic separator balances the differences in volumetric flow between a primary circuit (supply = Q_p) and a secondary circuit (demand = Q_s). Three operating situations can occur if a hydraulic separator is installed in a system, as shown below.

Cooling

Heating

Situation 1: $Q_p = Q_s$ $\Delta T_p = \Delta T_s$ $T_2 = T_4$

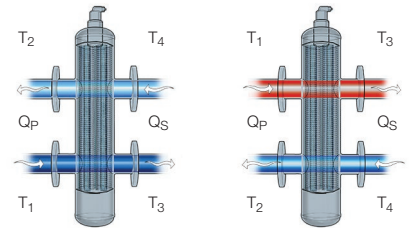

In this rare situation, supply and demand are exactly equal. This is the ideal situation in which the hydraulic separator operates primarily as a high efficiency air eliminator and dirt separator.

Situation 2: $Q_p < Q_s$ $\Delta T_p > \Delta T_s$ $T_2 = T_4$

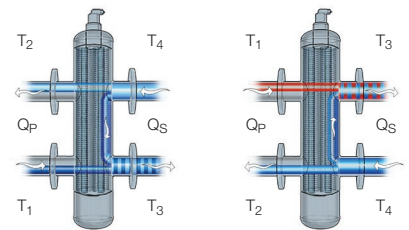

In this situation, demand is greater than supply. Some of the colder return water will join the supply, as a result of which it will take longer for the rooms to reach their set temperature. Where possible, the power of the boiler or chiller will then be increased.

Situation 3: $Q_p > Q_s$ $\Delta T_p < \Delta T_s$ $T_2 > T_4$

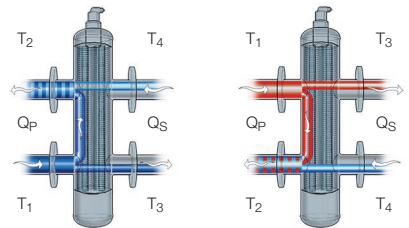

In the third situation, supply is greater than demand. Some of the warmer supply water will now join the return water, resulting in a decrease in the efficiency of the boiler or chiller. Where possible, the power will be modulated downwards.

Technical Specifications

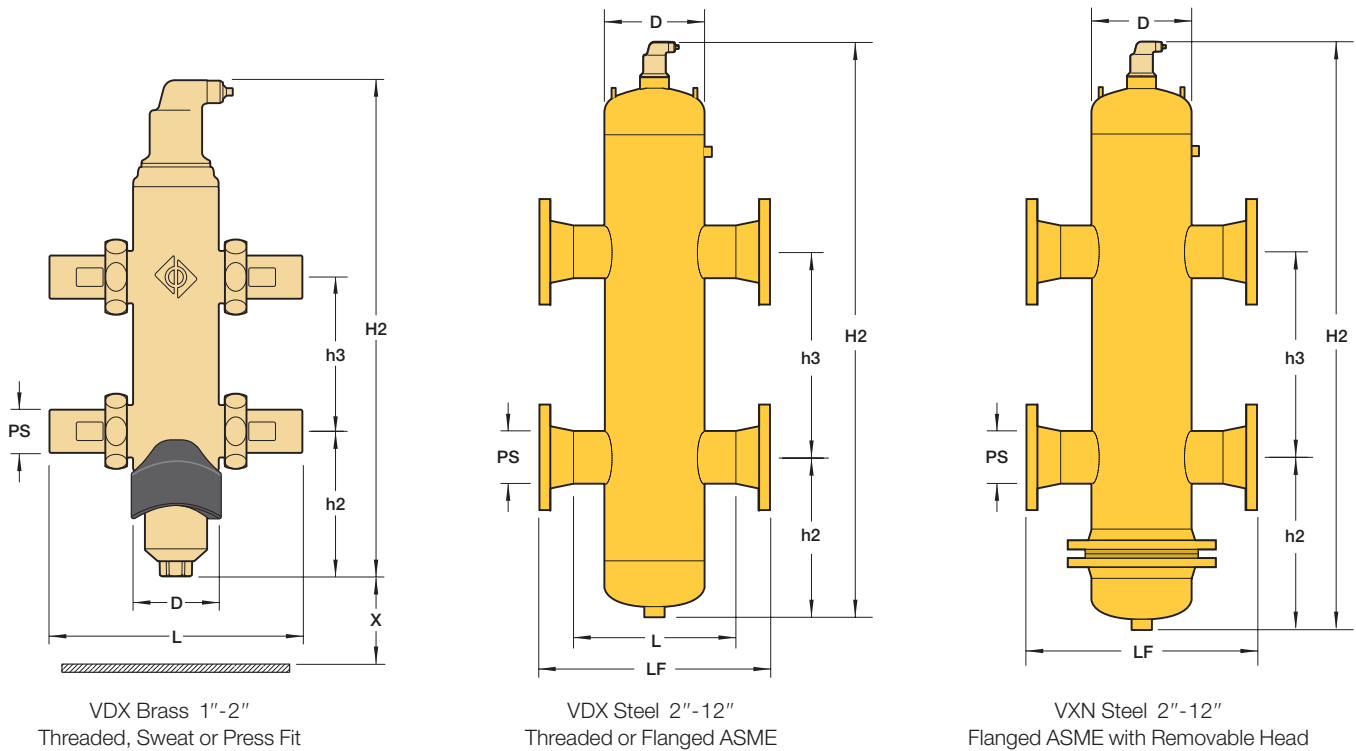

VDX Brass 1"-2"
Threaded, Sweat or Press Fit

VDX Steel 2"-12"
Threaded or Flanged ASME

VXN Steel 2"-12"
Flanged ASME with Removable Head

Steel

		VDX200MT	VDX250MT	VDX300MT	VDX400MT					
		VDX200FA	VDX250FA	VDX300FA	VDX400FA	VDX500FA	VDX600FA	VDX800FA	VDX1000FA	VDX1200FA
		VXN200FA	VXN250FA	VXN300FA	VXN400FA	VXN500FA	VXN600FA	VXN800FA	VXN1000FA	VXN1200FA
Pipe Size	inch	2	2 1/2	3	4	5	6	8	10	12
D	inch	6.6	6.6	8.6	8.6	12.8	12.8	16.0	20.0	24.0
H2	inch	32.0	36.0	39.0	50.0	61.0	70.0	91.0	113.0	133.0
h2	inch	9.4	9.9	10.6	13.8	17.4	19.9	26.6	32.9	39.2
h3	inch	9.5	12.0	14.0	18.0	22.0	26.0	34.0	42.0	50.0
L (Threaded)	inch	12.0	12.0	15.0	15.0	—	—	—	—	—
LF (Flanged)	inch	15.0	15.0	20.0	20.0	26.0	26.0	32.0	36.0	42.0
Volume	gal.	3.2	3.7	7.1	9.4	27	32	67	134	231
Weight (lbs)	MT	56	64	106	137	—	—	—	—	—
	FA	80	96	146	197	273	323	622	978	1747
	VXN	142	160	242	281	433	518	848	1380	2127
Recom. Flow*	GPM	60	90	140	240	370	540	940	1470	2090

Brass with Magnet (except 2")

		Threaded	VDX100FTM	VDX125FTM	VDX150FTM	VDX200FT**
		Sweat	VDX100SWM	VDX125SWM	VDX150SWM	VDX200SW**
		Press Fit	VDX100PFM	VDX125PFM	VDX150PFM	VDX200PF**
Pipe Size	inch		1	1 1/4	1 1/2	2
D	inch		3 1/2	3 1/2	3 1/2	4
H2	inch		20 1/4	20 1/4	20 1/4	30 1/4
h2	inch		7 3/8	7 3/8	7 3/8	8 1/4
h3	inch		5 3/8	5 3/8	5 3/8	10 1/4
L (Threaded)	inch		8 5/8	8 5/8	8 5/8	10 1/8
X	inch		4	4	4	4
Weight	lbs		13.2	14.3	15.4	26.4
Recom. Flow*	GPM		10	15	30	40

* Recommended Flow based on 6 ft./sec. Entering Velocity.

** Magnet not available.

All models designed as standard for 150 psig and 270°F.
Consult local sales office for higher ratings.



Spirotherm, Inc.
462 Camden Drive
Bloomington, IL 60108

Tel.: 630-307-2662
Fax: 630-307-3773
www.spirotherm.com
E-mail: info@spirotherm.com