

Submittal Data

| | | |
|-----------------------|------------------|-------------|
| PROJECT: | UNIT TAG: | QUANTITY: |
| REPRESENTATIVE: _____ | TYPE OF SERVICE: | DATE: _____ |
| ENGINEER: | SUBMITTED BY: | DATE: |
| CONTRACTOR: | APPROVED BY: | DATE: |
| | ORDER NO.: | DATE: |

MAGNA1 50-80 GF N



The Grundfos MAGNA1 N circulator pump is the stainless-steel variant of the MAGNA1 pump for applications where the liquid requires this, for example in domestic hot-water applications.

Note! Product picture may differ from actual product

| Conditions of Service | | Pump Data | | Motor Data | |
|-----------------------|--------|------------------------------|--------------|------------------|-------|
| Liquid: | Water | Liquid temperature range: | 14 .. 230 °F | Mains frequency: | 60 Hz |
| Temperature: | 140 °F | Maximum ambient temperature: | 104 °F | Enclosure class: | X4D |
| Specific Gravity: | 0.985 | Flange standard: | GF | | |
| | | Pipe connection: | GF53 | | |
| | | Product number: | 98126813 | | |

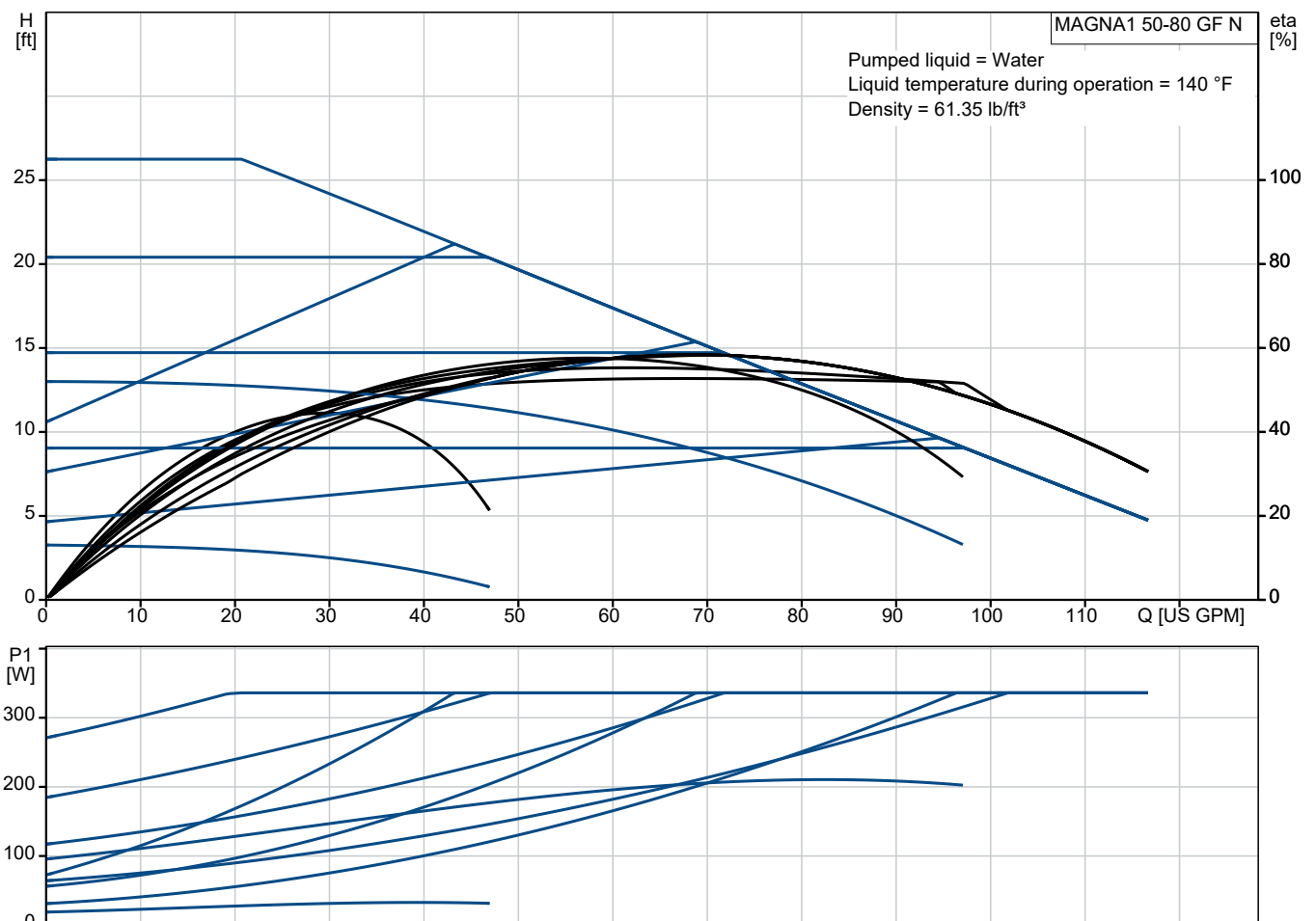

Submittal Data

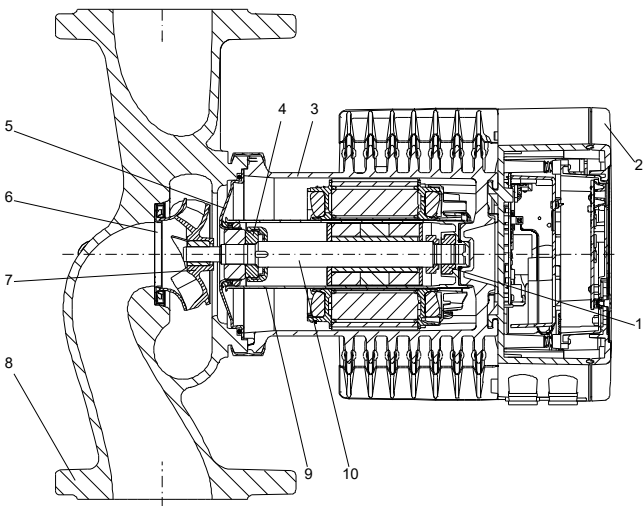
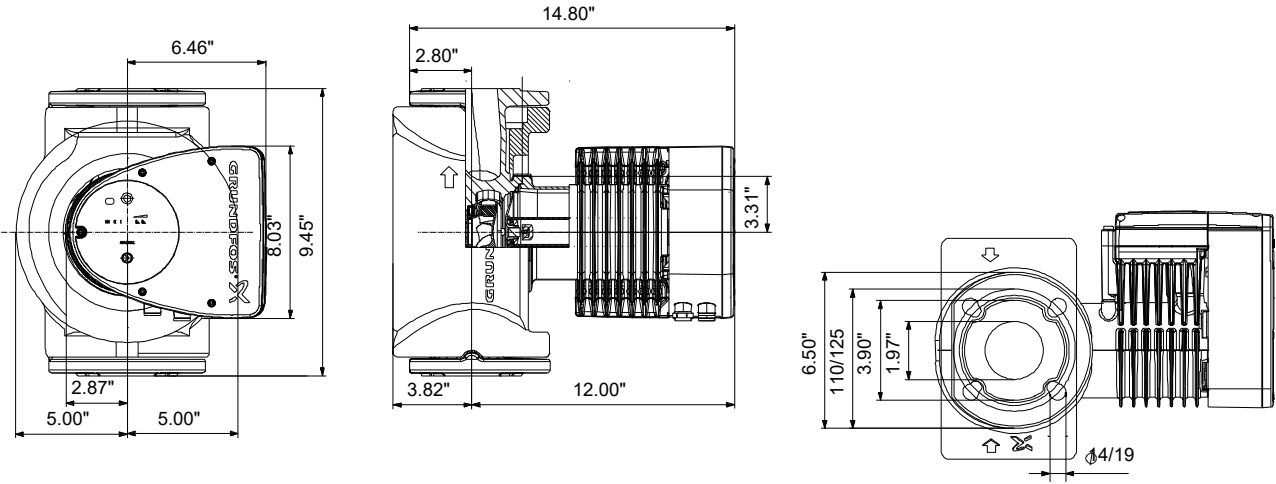

Materials:
 Pump housing: Stainless steel
 Pump housing: ASTM A351-CF8
 Impeller: Composite