

Submittal Data

PROJECT: _____	UNIT TAG: _____	QUANTITY: _____
REPRESENTATIVE: _____	TYPE OF SERVICE: _____	DATE: _____
ENGINEER: _____	SUBMITTED BY: _____	DATE: _____
CONTRACTOR: _____	APPROVED BY: _____	DATE: _____
	ORDER NO.: _____	DATE: _____



UPS 50-80/2 F

UPS is a three-speed circulator pump designed for heating and air-conditioning systems and is also used for central and district heating systems. The pump provides reliable and maintenance-free operation.

Note! Product picture may differ from actual product

Conditions of Service		Pump Data		Motor Data	
Liquid:	Water	Liquid temperature range:	14 .. 248 °F	Max. power input:	610 W
Temperature:	140 °F	Maximum ambient temperature:	104 °F	Rated voltage:	460 V
Specific Gravity:	0.985	Pipe connection:	GF 50	Mains frequency:	60 Hz
		Product number:	96402840	Enclosure class:	X4D
				Thermal protection:	EXT.

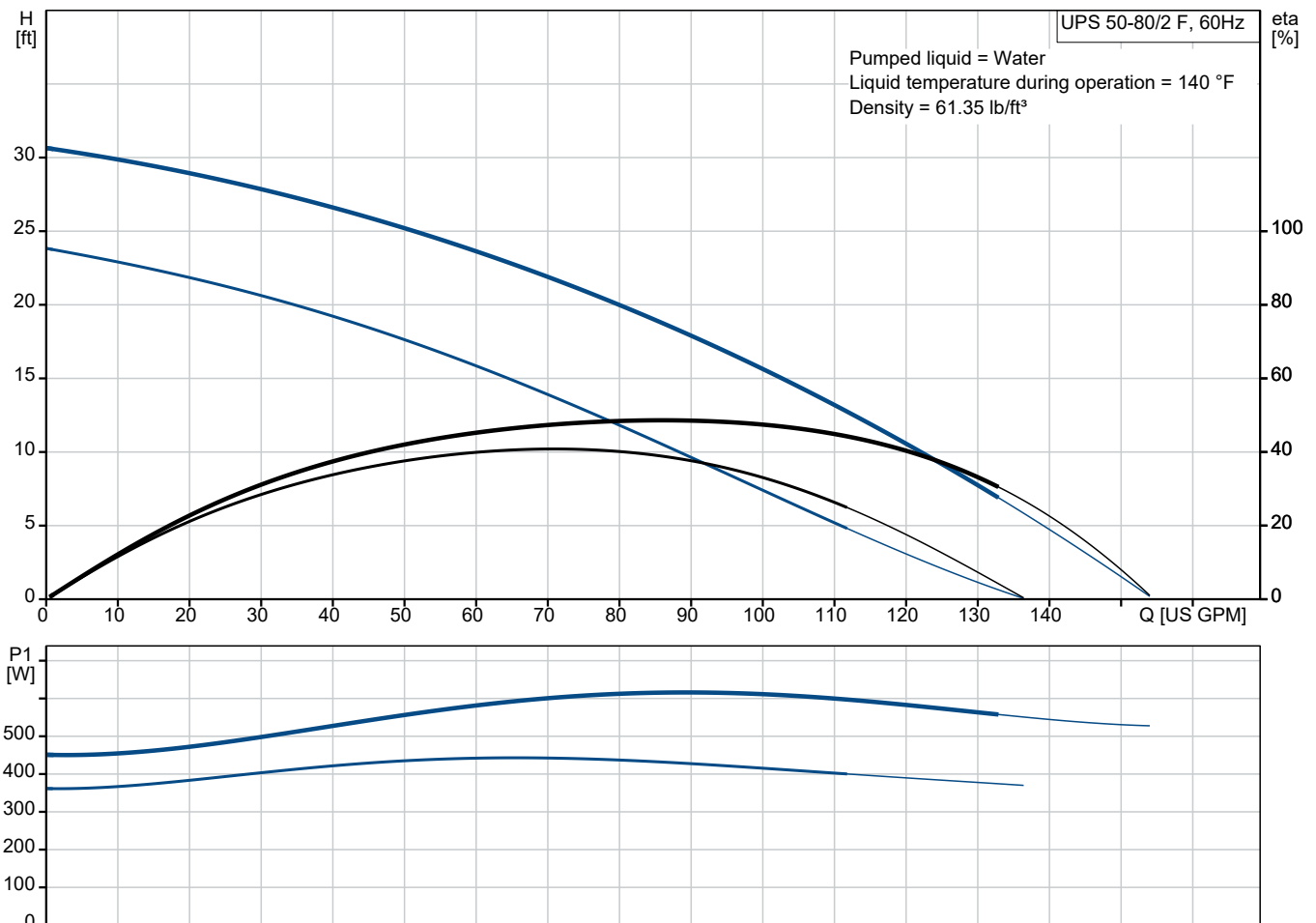

Submittal Data

4

3

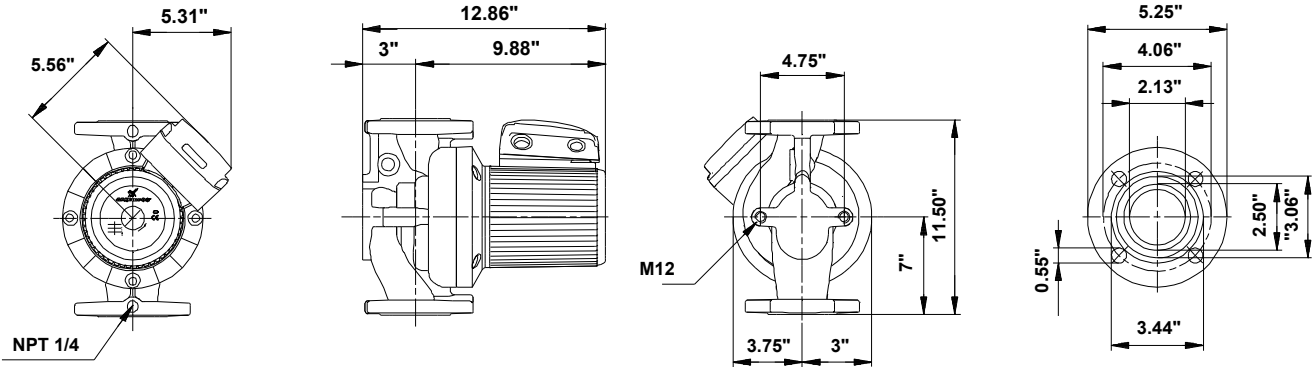

Materials:

- Pump housing: Cast iron
- Pump housing: ASTM 35 B - 40 B
- Impeller: Stainless steel
- Impeller: AISI 304
- Impeller: EN 1.4301

