

Thermal Solutions Boiler Control™ (TSBC™) Instruction Manual



Contents

Introduction	
Quick Reference	2
Overview	4
Product Features	
Boiler Sequence	6
Single Boiler Control Mode	9
Multiple Boiler Control Mode	10
EMS Boiler Control Mode	11
Manual Boiler Control Mode	14
Auxiliary Device	15
Front Panel	
Features	16
Display Mode	17
Menu Navigation	18
Setpoints Menu	19
Installation	
Terminal Layout	20
External Connections	21
Communication	23
Peer-To-Peer Network	25
RS485 Modbus Network	26
Setup & Tuning	
Boiler Configuration Menu	28
System Configuration Menu	29
Setup Menu	30
Manual Mode	35
Trouble Shooting	
Alarm Messages	36
Diagnostics Menu	38
Sensor Temperature vs. Resistance	41
Security Menu	42
Specifications	
General	43
Component Description & Repair Part Numbers	44
Appendix	
A. Parameter Summary	45
B. Customer Parameter Worksheet	47

Application

The Thermal Solutions Boiler Control™(TSBC™) has been designed for commercial hot water boiler applications.

Intent

This instruction manual includes detailed functional, installation and setup information. The intended users are application engineers, I&O manual and brochure writers, development and specifying engineers and installing contractors.

Material from this instruction manual is intended to be inserted into individual boiler operation manuals, supervisor instruction manuals, brochures and promotional and training materials.

IMPORTANT: THESE INSTRUCTIONS SHOULD BE USED IN CONJUNCTION WITH THE APPROPRIATE BOILER OR WATER HEATER INSTALLATION MANUAL.



TSBC™Front Panel
(Showing Power & Alarm LEDs,
2 Line 16 Character Message Display
and 4 Pushbuttons)

Introduction

Quick Reference

CONTROL MODE LCD Display	Outlet Sensor & Local SP Mode	Remote Sensor & Local SP Mode	Outlet Sensor & Remote SP Mode	Remote Sensor & Remote SP Mode	Remote Control Mode	Manual Mode
Typical Application	Single Boiler	Multiple Boilers	Energy Management System (EMS) Boiler Control			Manual Operation
			Single Boiler Setpoint Input	Multiple Boilers Setpoint Input	Modulation Rate Input	
Water Setpoint						
Temperature Sensor	Boiler Outlet	Remote System	Boiler Outlet	Remote System	Ignored	Ignored
Setpoint	Operator	Operator	Input (C+C-) or Modbus*	Input (C+C-) or Modbus*	Ignored	Ignored
"On" and "Off" Point	Operator	Operator	Operator	Operator	Ignored	Ignored
Outdoor Air Reset	Option	Option	Ignored	Ignored	Ignored	Ignored
Domestic Hot Water Priority (DHWP)	Option	Option	Ignored	Ignored	Ignored	Ignored
Warm Weather Shutdown (WWSD)	Option	Option	Option	Option	Option	Ignored
Call For Heat						
Call For Heat	Based on Setpoints	Based on Setpoints	Based on Setpoints	Based on Setpoints	Input (RO) or Modbus	Manually Set
Modulation Rate						
Internal Boiler Control	Based on Setpoint	Based on Setpoint	Based on Setpoint	Based on Setpoint	Ignored	Ignored
Lead Boiler Control	Peer-to-Peer Connected	With Peer-to-Peer Connected	With Peer-to-Peer Connected	With Peer-to-Peer Connected	Ignored	Ignored
Remote EMS Control	Ignored	Ignored	Ignored	Ignored	Input (C+C-) or Modbus	Ignored
Manual Control	Ignored	Ignored	Ignored	Ignored	Ignored	By Operator
Remote Connections						
Local / Remote Input (LR)	Ignored	Ignored	Closed	Closed	Closed	Ignored
Remote On/Off (Enable) Input (RO)	Enable/Disable	Enable/Disable	Enable/Disable	Enable/Disable	On/Off	Ignored
Remote Control Input (C+C-)	No	No	Remote Setpoint	Remote Setpoint	Remote Modulation	Ignored
Communication Network	Peer-To-Peer or Modbus*	Peer-To-Peer or Modbus*	Peer-To-Peer or Modbus*	Peer-To-Peer or Modbus*	Modbus Only	Modbus Only
Additional Information	Page 9	Page 10	Page 11	Page 12	Page 13	Page 14

* If Modbus is selected the Peer-To-Peer Network can not be used. Modulating Lead/Lag features require the Peer-To-Peer Network.

Introduction

Quick Reference

Abbreviation List

Abbreviation	Description
AL	Flame Safeguard Alarm
BIT	Boiler Inlet Temperature
BOT	Boiler Outlet Temperature
BP	Boiler Pump
BV	Blocked Vent Switch
C	Common Termination Point
CA	Low Combustion Air Flow
CH	Call For Heat (CFH)
CS	Fuel Valve Energized
DH	Domestic Hot Water Heating Demand
DP	Domestic Hot Water Priority (DHWP)
TSBC	Sage Boiler Control
EMS	Energy Management System
GP	High and Low Gas Pressure Switches
HL	High Limit Aquastat
HP	High Pressure Gas Switch
IN	Boiler Inlet Water Temperature
LC	Low Water Cutoff Switch
LL	Lead Lag
LO	Lockout Indicator
LR	Local / Remote
M	Electric Motor
Mix	3 Way Mixing Valve
OA	Outside Air Temperature
OL	Operating Limit Aquastat
OO	Burner On / Off Switch
OUT	Boiler Outlet Water Temperature
RO	Remote On / Off
RST	Remote System Temperature
SH	Space Heating Demand
SI	Spare Input (Programmable)
SO	Spare Output (Programmable)
SP	Setpoint (As found in "Operational SP" and "Remote SP")
SP	System Pump
VI	Vent Inducer
WF	Low Water Flow
WWSD	Warm Weather Shutdown

Termination Number Identification (Typical):

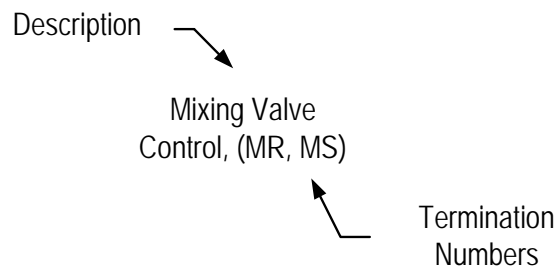

Introduction

Overview

Thermal Solutions Boiler Control Overview

The Thermal Solutions Boiler Control (TSBC) is a complete boiler monitoring and automation system. The TSBC provides advanced boiler modulation, operating control, diagnostics, multiple boiler lead-lag and auxiliary device control. The TSBC provides advanced control features in an easy to use package.

Flexible, Field Selectable Control

Control modes, water system, boiler auxiliary and modulating lead/lag control features are menu selectable without the need for external programmers, laptops or down loads. Every boiler is shipped with factory defaults that make field menu selections unnecessary unless you are applying additional control features.

Boiler Monitoring and Diagnostic Displays

The TSBC's two line by sixteen character LCD display may be used for monitoring boiler inlet and outlet, remote system and outside air temperatures, modulation rate setpoint and modulating percent and mixing valve demand percent. Additionally, the display automatically presents boiler sequence messages, alarms, hold and lockout messages. A diagnostic menu is included that provides the last 10 alarm messages and boiler inlet temperature alarm history. Boiler inlet temperature alarm history includes time and date, the lowest inlet temperature reached and the amount of time the water temperature dropped below the alarm setpoint.

Modulation Rate and On/Off Modes

The TSBC may simply control boiler modulation and on/off output based on the boiler water outlet temperature and an operator adjusted setpoint. However, using parameter selections, the TSBC allows the boiler modulation and on/off output to respond to remote system water and outside air temperatures, Domestic Hot Water Priority (DHWP) input or Energy Management System (EMS) modulation rate demand, remote setpoint or remote start/stop commands. Parameter selections of remote system water temperature and remote mode determine the choice of one of six different control modes.

Advanced Availability

The above control modes are menu selectable options. However, if a selected sensor fails, the TSBC automatically changes to a control mode that will allow continued automatic operation of the boiler. For example, in the event of a remote system temperature sensor failure, the TSBC will automatically switch to boiler outlet temperature sensor based control.

Outdoor Air Reset

When selected the modulation rate setpoint is automatically adjusted based on outside air temperature. Outdoor air "reset" setpoint saves fuel by adjusting the water temperature of a heating boiler lower as the outside air temperature increases.

Warm Weather Shutdown (WWSD)

Some boilers are used primarily for heating buildings, and the boilers can be automatically shutdown when the outdoor air temperature is warm. When outside air temperature is above the WWSD setpoint, this function will prevent the boiler, boiler pump and/or the system pump from starting.

Domestic Hot Water Priority (DHWP)

Some boilers are used primarily for building space heating, but also provide heat for the domestic hot water users. When the outdoor temperature is warm, the outdoor reset setpoint may drop lower than a desirable domestic hot water temperature. When enabled and a DHWP contact input is detected, the hot water setpoint is adjusted to be greater than a field adjustable DHWP Setpoint.

Water Side Control Outputs

In order to maximize the life and availability of a hot water systems it may be desirable to automate mixing valves, boiler pumps, system pumps, and standby system pumps. The TSBC makes this type of automation totally integrated and cost effective. The control of these devices is field selectable through simple yes/no menu selections.

Combustion Air Side Control Outputs

Boiler room Combustion air dampers (fresh air dampers) and Vent Inducer control outputs are field selectable options.

Peer-To-Peer Network

The TSBC includes state-of-the-art modulating lead-lag sequencer for up to eight (8) boilers capable of auto rotation, outdoor reset and peer-to-peer communication. The peer-peer network is truly "plug and play". Communication is activated by simply connecting a RJ11 telephone line between boilers. The TSBC provides precise boiler coordination by sequencing boilers based on both remote system water temperature and boiler modulation rate. For example, the lead boiler can be configured to start a lag boiler after operating above 90% modulation rate for longer than an adjustable time. The boilers are modulated in "unison" (parallel) modulation rate to ensure even heat distribution

Modbus Communication Interface

A factory configured RS485 Modbus interface is available for Energy Management System (EMS) or SCADA system monitoring and control.

Introduction

Overview

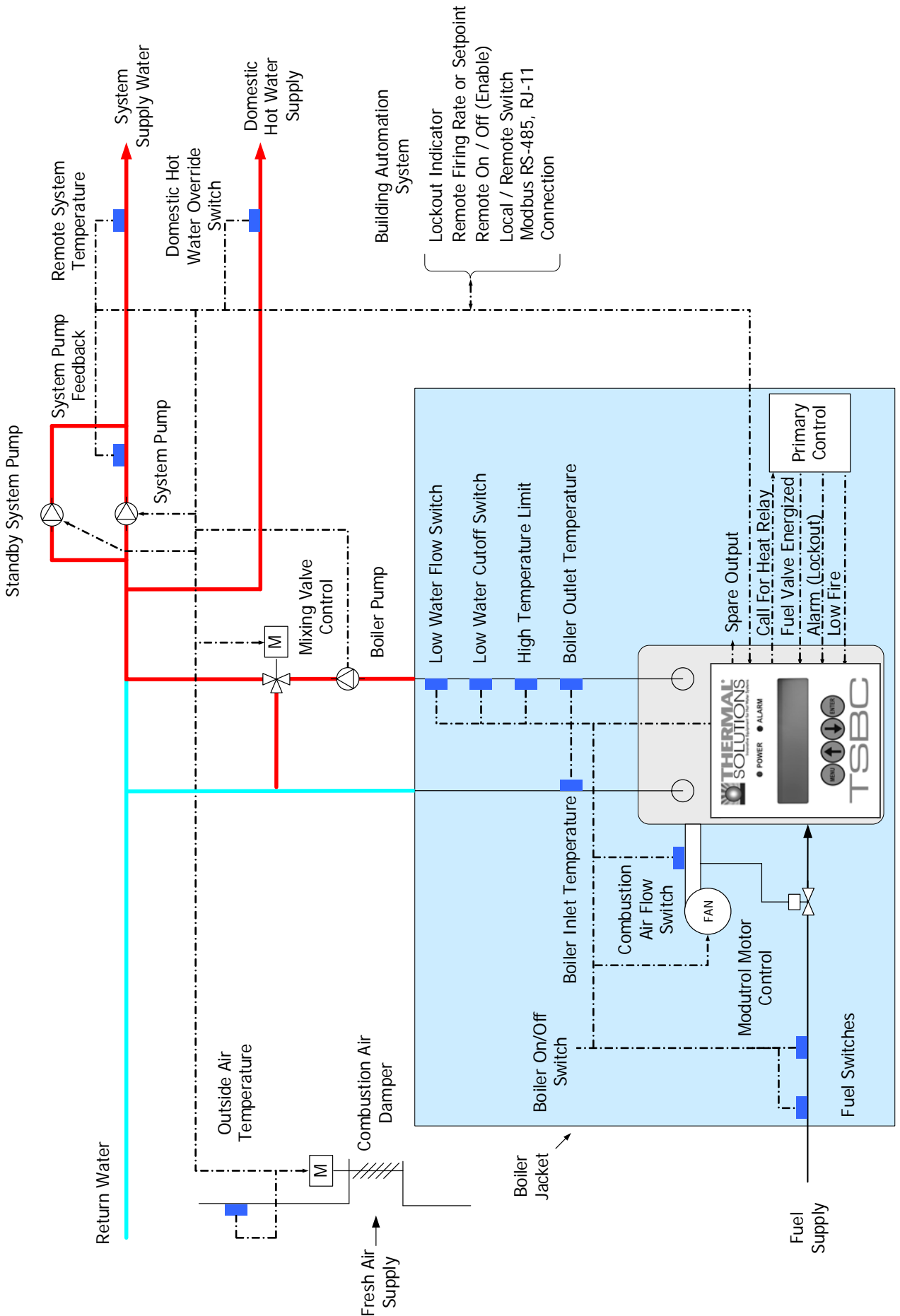

Thermal Solutions Boiler Control

Boiler Sequence

BOILER STATE LCD Display		Terminal Number	Parameter/Note	Pre-Sequence States				Start/Stop Sequence States								
				Boiler Disable	Warm Weather Shutdown	Lockout	Standby	Pump Purge	Limit Hold	Purge / Pilot Ignition	Low Fire / Ignition	Main Ignition	Low Fire Hold	Boiler Running	Fan Post Purge	Pump Cooldown
Parameter / Notes				a	b &c	a	a	3/d	-	-	-	-	53	-	54/d	4/d
Interlock Inputs	Boiler Disable or Remote On/Off	RO	-					Boiler Enable/Disable On								
	Outdoor Air Temp > Warm Weather Shutdown Setpoint	O+,O-	44,30,75													
	Domestic Hot Water Priority	DP	20,74					Domestic Hot Water Demand Monitored								
	Low Fire Hold	SI	9													
	Fuel Valve Energized	CS	-													
	Flame Safeguard Alarm	AL	-													
	System Pump Feedback	SI	9					System Pump Feedback Monitored								
	Call For Heat	R+,R- OR B,Q,B,C	70,71,72					Call For Heat								
Limits Inputs	Recycling Limits (LC, OO, WF, GP and HL input)	LC, OO, WF, GP, HL	8,27,28					Recycling Limits Made								
	Non-Recycling Limits (Combustion Air Flow (CA Input))	CA	-					Non-Recycling Limits Made								
Relay Outputs	Call For Heat Relay	CH	-					Call For Heat Relay On								
	Lockout Indicator (Manual Reset Required)	LO	-													
	Spare Output	VI	-					Spare Output On								
	Boiler Pump	BP	2,30					Boiler Pump On								
	System Pump	SP	25,30					System Pump On								
	System Pump Backup Pump	SO	10					Starts in response to System Pump Feedback Input SI								
	Combustion Air Damper	SO	10,27/e					Combustion Air Damper Open								
	System Alarm	SO	10					Alarm Status is Monitored								
Modulation Outputs	Mixing Valve Output	MS,MR	6,79,80					Modulate								
	Firing Rate	Blower High Speed	V+,V-, P+,P-	49												
		Purge %	V+,V-, P+,P-	52												
		Modulation	V+,V-, P+,P-	-												
		Low Fire %	V+,V-, P+,P-	9,51/f												
		Blower 0 Volts	V+,V-, P+,P-	50												

Notes

- a. Boiler Pump is "On" when the Boiler Pump is set to "On Always" or the boiler is lead boiler and Boiler Pump is set to "On Lead".
- b. Boiler Pump is "On" when the Boiler Pump is set to "On Always" and WWSD is set to "WWSD of System Pump" or "Off".
- c. System Pump is "On" when the System Pump is set to "yes" and WWSD is set to either "WWSD of Boiler" or "Off".
- d. Boiler pump is "On" during Prepurge and Post Purge when Boiler Pump is set to "Purge" or boiler is lead & Boiler Pump is set to "On Lead".
- e. Combustion Air Damper Spare Output is maintained "On" for 2 minutes after the Call For Heat is removed.
- f. Modulation rate is held at purge % when low fire input is not provided.

Product Features

Boiler Sequence (Continued)

Pre-Sequence States

BOILER STATE LCD Display	CONTROL MODE LCD Display	Description
Boiler Disabled	Any Mode (Except for Remote Control)	Boiler is prevented from starting, Remote On/Off (Enable) (Terminal RO) Input is not energized.
Warm Weather Shutdown	Any Mode (Except for Manual Mode)	Boiler is prevented from starting, Warm Weather Shutdown (WWSD) is enabled and outside air temperature is above the WWSD Setpoint.
Lockout	Any Mode	Boiler is prevented from starting, Flame Safeguard lockout is present. A Flame Safeguard manual reset is required.
Standby	Outlet Sensor & Local SP Mode	Control monitors boiler outlet temperature, a Call For Heat is initiated when boiler outlet temperature is below the Operational Setpoint.
	Remote Sensor & Local SP Mode	Control monitors Remote System Temperature, a Call For Heat is initiated when Remote System Temperature is below the Operational Setpoint.
	Outlet Sensor & Remote SP Mode	Control monitors boiler outlet temperature, a Call For Heat is initiated when boiler outlet temperature is below the Remote Setpoint Input (Terminal C+,C- or Modbus Interface).
	Remote Sensor & Remote SP Mode	Control monitors Remote System Temperature, a Call For Heat is initiated when Remote System Temperature is below the Remote Setpoint Input (terminal C+,C- or Modbus Interface).
	Remote Control Mode	Control monitors Remote On/Off (Enable) input (Terminal RO or Modbus Interface), a Call For Heat is initiated when input is energized.
	Manual Operation Mode	A Call For Heat is initiated when Manual Mode Menu item Boiler On/Off is set to On.

Start/Stop Sequence States

BOILER STATE LCD Display	CONTROL MODE LCD Display	Description
Pump Purge	Any Mode (Except Manual Mode)	Once a Call For Heat is initiated and Boiler Pump Purge is selected, the pump output is energized until the Pump Prepurge Time is complete. If the Call For Heat condition still exists at the end of the Prepurge Time (the temperature of the water at the sensor may rise with boiler water flowing passed it) the pump will continue to operate and the Call For Heat Relay is energized.
Limit Hold	Any Mode	Power is applied to the safety limit string. If any limits does not pass power (is not energized), the alarm LED and LCD display shows the reason the start sequence is on Hold. Refer to Trouble shooting section for explanation of individual lockout and alarm messages.
Purge / Pilot Ignition	Any Mode	After the limit string passes power, the fan is started, the modulation output is set to Purge Rate. When the purge period is complete, the flame safeguard sequences on the ignition transformer and pilot.
Low Fire / Ignition	Any Mode	When the Spare Input Low Fire is selected, modulation output is set to the Low Fire Speed when the Spare Input is energized.
Main Ignition	Any Mode	The main gas valve input is energized and the modulation output is held constant for an ignition stabilization period.
Low Fire Hold	Any Mode	The modulation output is held at the Low Fire for the Low Fire Hold time.
Boiler Running	Any Mode	When this Low Fire Hold time is complete, the modulation output is released to modulate.
Fan Post Purge	Any Mode	When water temperature is above setpoint, there is a Flame Safeguard or Limit fault, the Call For Heat is ended and the modulating output is set to Purge Rate for the Post Purge Time.
Pump Cooldown	Any Mode	When Boiler Pump Purge is selected, the boiler pump remains "on" until the boiler outlet temperature is less than the Post Purge Delta (default is 5 F) above the Boiler Inlet Temperature.

Product Features

Boiler Sequence (Continued)

Multiple Boilers

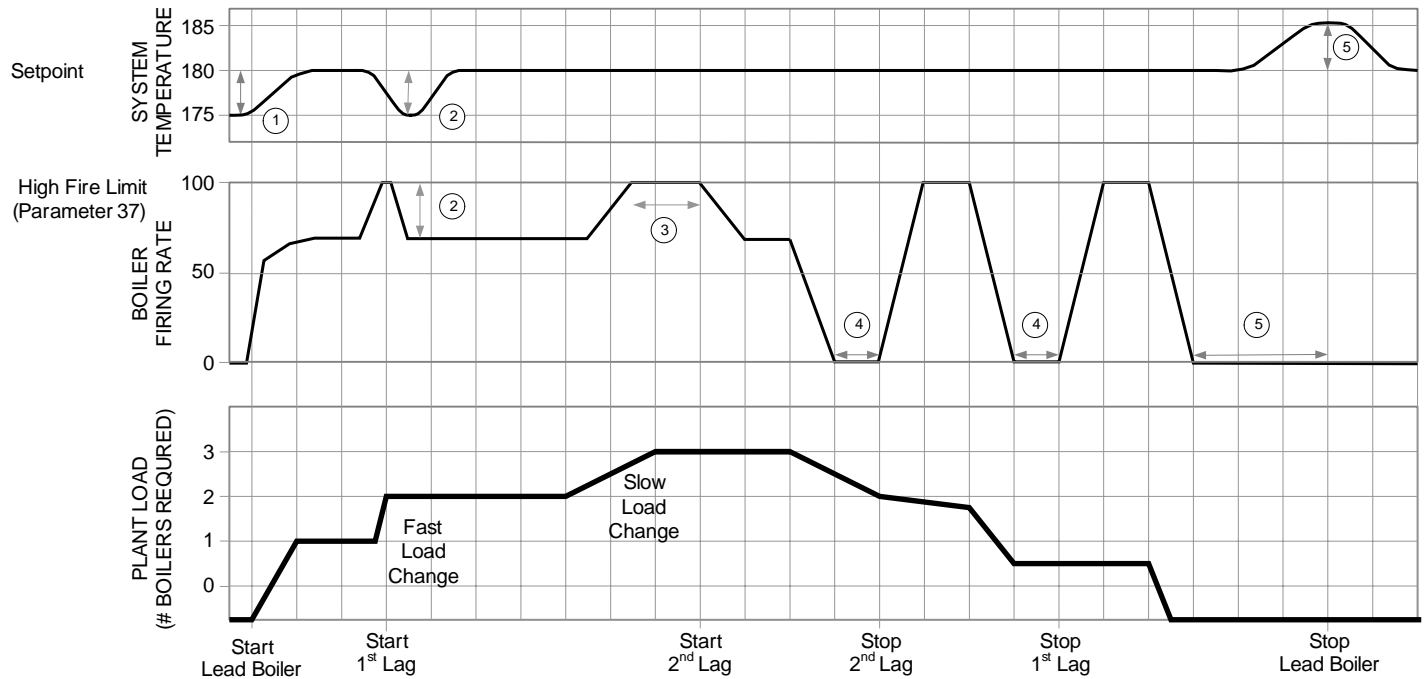

Boiler Start and Stop Peer-To-Peer Network Sequence Diagram
(3 boiler system shown, typical for up to 8 boilers)

- ① - **Lead Boiler Start**
Water temperature is below the setpoint by more than the “On Point” differential.
- ② - **Temperature Based Lag Boiler Start**
Water temperature is below the setpoint by more than the “On Point” differential for longer than the adjustable time delay (“Boiler On Delay” parameter).
- ③ - **Modulation % Based Lag Boiler Start**
The boiler modulation rate has been above the adjustable limit (“LL Start Trigger” parameter) for longer than the time delay.
- ④ - **Lag Boiler Stop**
The boiler modulation rate has been below the adjustable limit (“LL Stop Trigger” parameter) for longer than the time delay. Additionally, lag boilers are stopped when water temperature is above the setpoint by more than the “Off Point” differential for longer than the “Boiler Off Delay” parameter).
- ⑤ - **Lead Boiler Stop**
The last boiler remains on line until the water temperature is above the “Off Point” setpoint for longer than the time delay.

Notes

- The “Boiler Address” parameter assignment determines the boiler sequencing order.
- The Lead Boiler automatically rotates (when “Rotate” parameter is enabled) based on field adjusted time (“Rotate After” parameter, default is 168 hours). When rotating, the lead boiler will move to the end of the lag order and the 1st lag boiler will become the lead. The rest of the boilers will then move up in the lag order accordingly.
- Lead Boiler is the first boiler to turn on and the last boiler to turn off, (First On, Last Off, FOLO).
- Lag Boilers are turned on in order and turned off in reverse order, (First On, Last Off, FOLO).
- Tripped boilers are replaced without waiting for the Boiler On Delay timer. If a tripped boiler becomes available it is returned to service.

Product Features

Single Boiler Control

Display Shows: Outlet Sensor & Local SP Mode

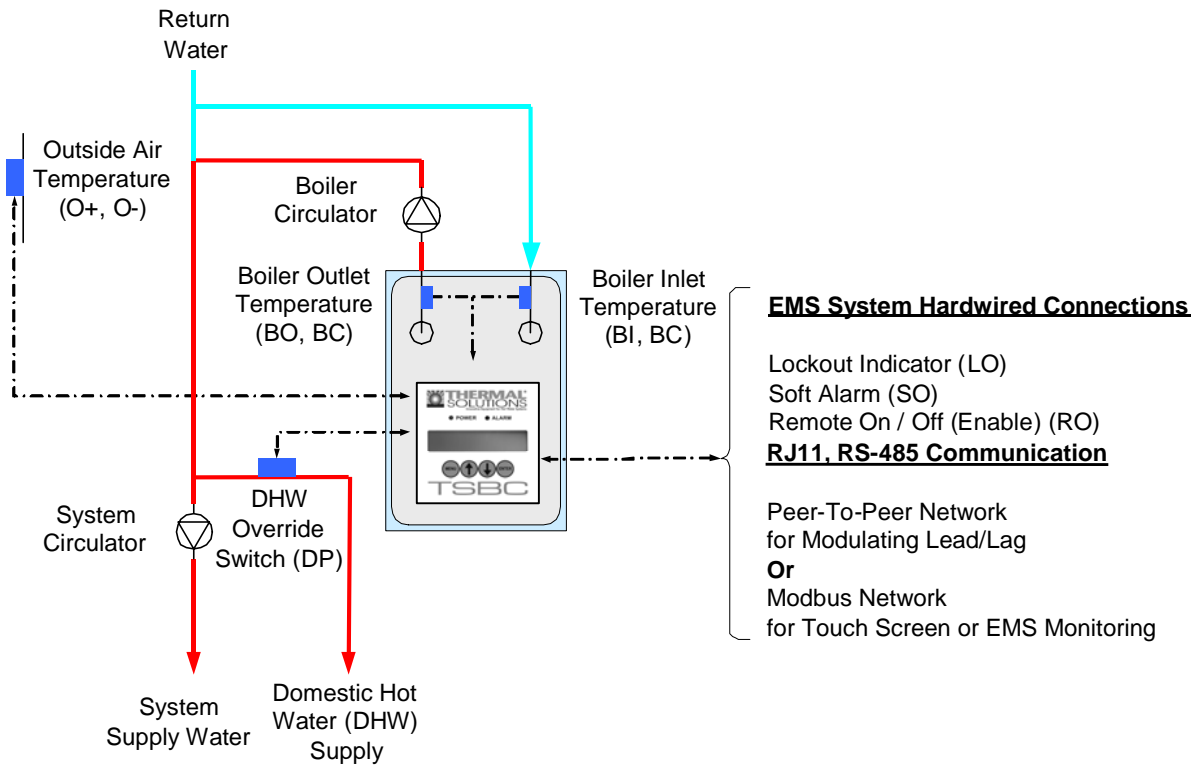

Outlet Sensor & Local SP Mode Application Diagram
(Showing Relevant Connections)

Features

Setpoints

The operator selects the setpoint and on and off points from the LCD display.

Modulation Rate Control

Boiler automatically modulates to maintain the boiler outlet temperature at setpoint.

Call for Heat

The Call For Heat is determined by the setpoint, on and off points and boiler outlet temperature.

Options

Outside Air Reset

If enabled, the Outside Air Sensor will automatically adjust the setpoint.

Warm Weather Shutdown (WWSD)

If enabled, the WWSD will disable a boiler start when outside air temperature is above a Warm Weather Shutdown (WWSD) setpoint.

Domestic Hot Water Priority (DHWP)

If enabled, the DHWP will adjust the setpoint to satisfy the DHWP setpoint when a DHWP input (DP) is energized.

Selecting This Control Mode

To select Outlet Sensor & Local SP Mode set the following parameters:

System Configuration Menu:

Remote Control = "No"

Remote System Temperature Sensor = "No"

Remote On / Off (Enable) Input (RO) = Closed (Jumper (RO) to (C))

If the Remote On / Off (Enable) (RO) input is opened, the Call For Heat Relay (CH) is de-energized.

Modbus Network

To establish a Modbus network set the following parameters:

Communication Menu:

Protocol = Modbus

Modbus Address = Give each boiler a unique address.

Baud Rate = Set identical to remote system.

Parity = Set identical to remote system.

Connect all boilers using a RJ11 ended telephone cable.

If the Modbus network is activated the remote system may monitor and/or control boiler operation. Refer to page 26 for additional information.

Product Features

Multiple Boiler Control

Display Shows: Remote Sensor & Local SP Mode

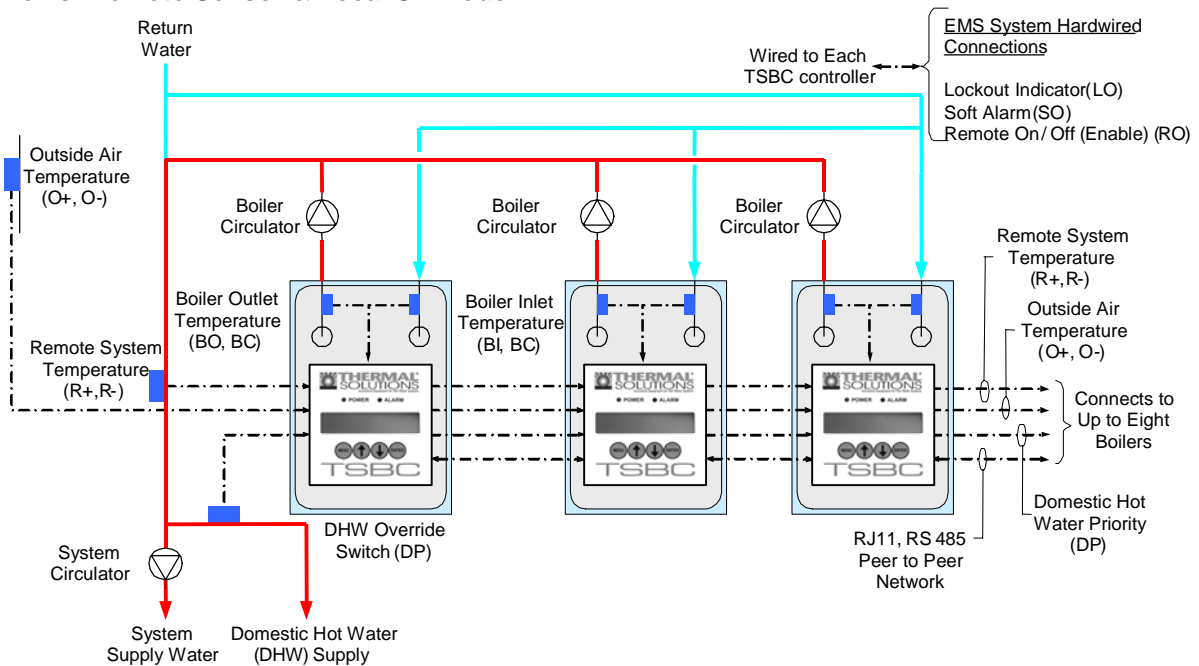

Remote Sensor & Local SP Mode Application Diagram
(Showing relevant connections for 3 boilers, typical for up to 8)

Features

Setpoints

The operator selects the setpoint and on and off points from the LCD display.

Modulation Rate Control

Boiler automatically modulates to maintain the Remote System Temperature (RST) at setpoint.

Call for Heat

The Call for Heat is determined by setpoint, on and off points and RST. If a Peer-To-Peer network is activated, a Call for Heat is also initiated when the Lead boiler modulation rate % is above an adjustable High Fire Rate Limit (parameter 37) for too long a time.

Options

Outside Air Reset

If enabled, the Outside Air Sensor will automatically adjust the setpoint.

Warm Weather Shutdown (WWSD)

If enabled, the WWSD will disable a boiler start when temperature is above a Warm Weather Shutdown (WWSD) setpoint.

Domestic Hot Water Priority (DHWP)

If enabled, the DHWP will adjust the setpoint to satisfy the DHWP setpoint when a DHWP contact input (DP) is closed. When multiple boilers monitor the DHWP input, an isolated contact is required for each boiler.

Selecting This Control Mode

To select Remote Sensor & Local SP Mode set the following parameters:

System Configuration Menu:

Remote Control = "No"

Remote System Temperature Sensor = Control

Remote On / Off (Enable) Input (RO) = Closed (Jumper (RO) to (C))

If the Remote On / Off (Enable) (RO) input is opened, the Call For Heat Relay (CH) is de-energized.

If the Remote System Temperature Sensor (RST) fails, the control mode is automatically switched to Outlet Sensor & Local SP Mode.

Peer-To-Peer Network

To establish a Peer-To-Peer network follow the procedure provided on page 25.

If the Peer-To-Peer network is activated the Lead boiler controls modulation rate and Call for Heat for all networked boilers. Up to 8 networked boilers are fired in "Unison" (all at the same modulation rate).

Product Features

Energy Management System (EMS) Boiler Control

Display Shows: Outlet Sensor & Remote SP Mode

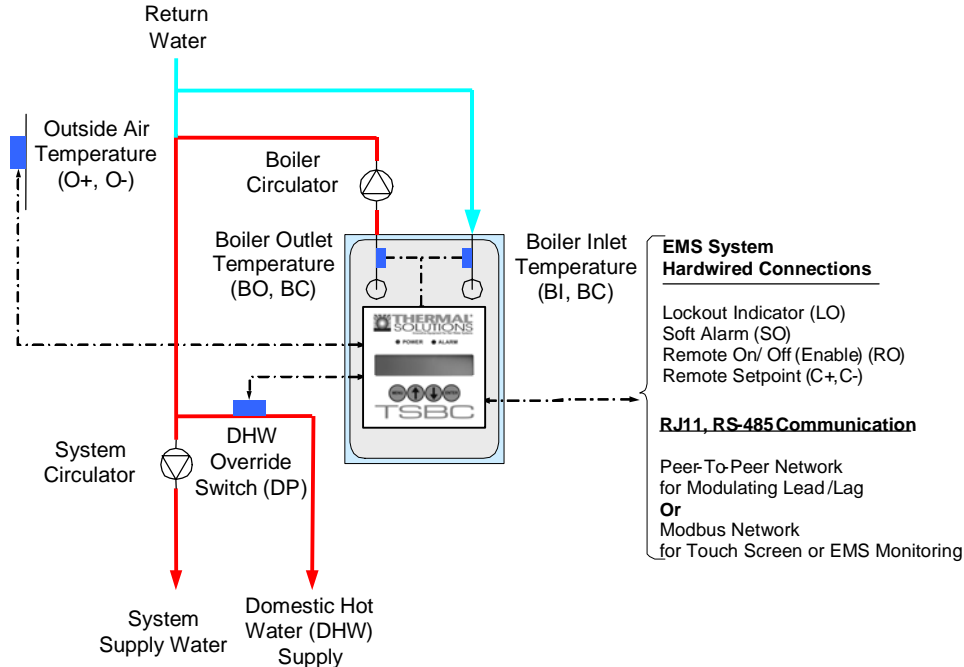

Outlet Sensor & Remote SP Mode Application Diagram
(Showing relevant connections)

Features

Setpoints

The setpoint is determined by the Remote Input (C+,C-) or Modbus Input and operator sets the on and off points from the LCD display.

Modulation Rate Control

Boiler automatically modulates to maintain the boiler outlet temperature at setpoint.

Call for Heat

The Call For Heat is determined by setpoint, on and off points and boiler outlet temperature.

Options

Warm Weather Shutdown (WWSD)

If enabled, the WWSD will disable a boiler start when temperature is above a Warm Weather Shutdown (WWSD) setpoint.

Outside Air Temperature may be displayed only. Outside Air Reset and Domestic Hot Water Priority input (DP) are ignored.

Selecting This Control Mode

To select Outlet Sensor & Remote SP Mode set the following parameters:

System Configuration Menu:

Remote Control = "Remote SP"

Remote System Temperature Sensor = "No"

Local / Remote Input (LR) = Closed

Remote On / Off (Enable) Input (RO) = Closed (Jumper (RO) to (C))

When the Local / Remote Input (LR) is open, Remote Input (C+,C-) is ignored and Outlet Sensor & Local SP Mode is active.

If the Remote On / Off (Enable) (RO) input is opened, the Call For Heat Relay (CH) is de-energized.

Modbus Network

To establish a Modbus network set the following parameters:

Communication Menu:

Protocol = Modbus

Modbus Address = Give each boiler a unique address.

Baud Rate = Set identical to remote system.

Parity = Set identical to remote system.

Connect all boilers using a RJ11 ended telephone cable.

If the Modbus network is activated the remote system may monitor and/or control boiler operation. Refer to page 26 for additional information.

Product Features

Energy Management System (EMS) Boiler Control (continued)

Display Shows: Remote Sensor & Remote SP Mode

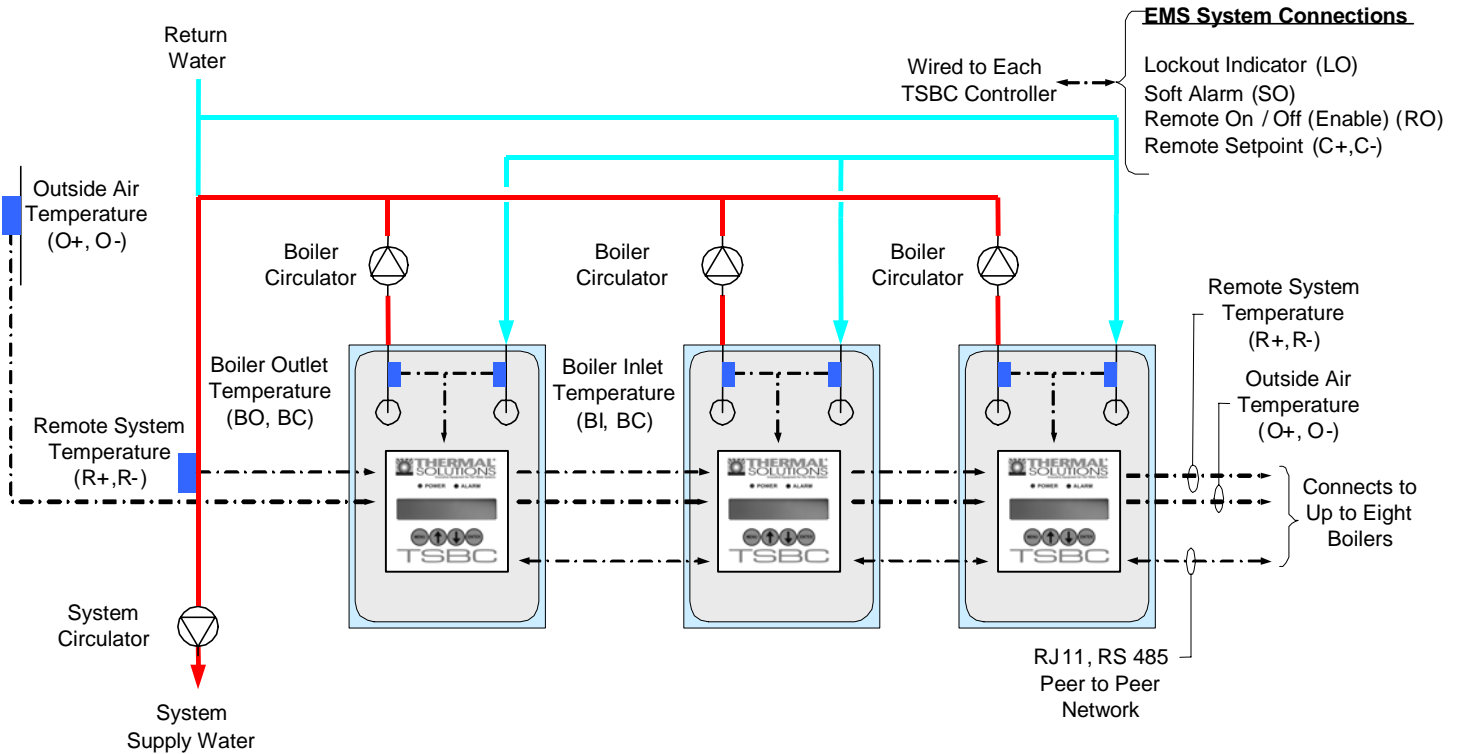

Remote Sensor & Remote SP Mode Application Diagram
(Showing relevant connections for 3 boilers, typical for up to 8)

Features

Setpoints

The setpoint is determined by the Remote Input (C+, C-) and operator sets the on and off points from the LCD display.

Modulation Rate Control

Boiler automatically modulates to maintain the Remote System Temperature (RST) at setpoint.

Call for Heat

The Call For Heat is determined by setpoint, on and off points and Remote System Temperature. If a Peer-To-Peer network is activated, a Call for Heat is also initiated when the Lead boiler modulation rate % is above an adjustable High Fire Rate Limit (Parameter 37) for too long a time.

Options

Warm Weather Shutdown (WWSD)

If enabled, the WWSD will disable a boiler start when temperature is above a Warm Weather Shutdown (WWSD) setpoint.

Outside Air Reset and Domestic Hot Water Priority input (DP) are ignored.

Selecting This Control Mode

To select Remote Sensor & Remote SP Mode set the following parameters:

System Configuration Menu:

Remote Control = "Remote SP"

Remote System Temperature Sensor = Control

Local / Remote Input (LR) = Closed (Jumper (LR) to (C))

Remote On / Off (Enable) Input (RO) = Closed (Jumper (LR) to (C))

When the Local / Remote Input (LR) is open, Remote Input (C+, C-) is ignored and Remote Sensor & Local SP Mode is active.

If the Remote On / Off (Enable) (RO) input is opened, the Call For Heat Relay (CH) is de-energized.

Peer-To-Peer Network

To establish a Peer-To-Peer network follow the procedure provided on page 25.

If the Peer-To-Peer network is activated the Lead boiler controls modulation rate and Call for Heat for all networked boilers. Up to 8 networked boilers are fired in "Unison" (all at the same modulation rate).

Product Features

Energy Management System (EMS) Boiler Control (continued)

Display Shows: Remote Control Mode

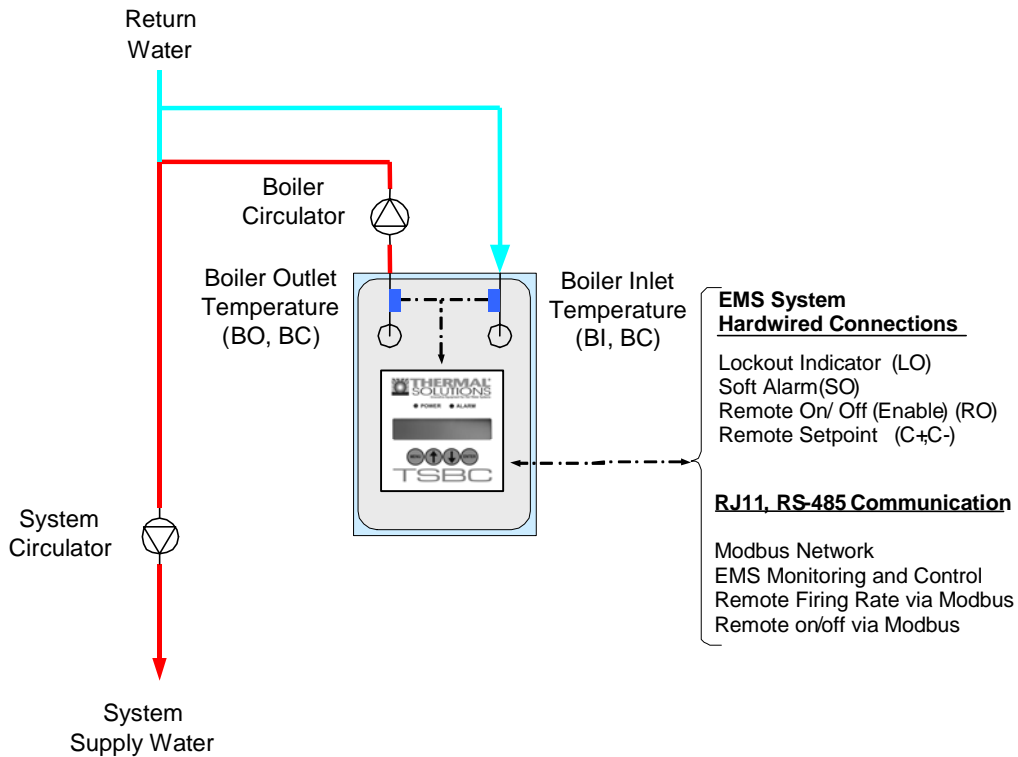

Remote Control Mode Application Diagram
(Showing relevant connections)

Features

Modulation Rate Control

The Remote Input (C+,C-) or Modbus input sets modulation rate. The setpoint is ignored.

Call for Heat

The Call For Heat is determined by Remote On/Off input (RO) or Modbus input. The on and off points are ignored. The boiler will turn off if the water temperature increases past the temperature set on the Operational Temperature Limit.

Options

Outside Air Reset and Domestic Hot Water Priority input (DP) and Warm Weather Shutdown are ignored.

Selecting This Control Mode

To select Remote Control Mode set the following parameters:

System Configuration Menu:

Remote Control = "Remote Mod"

Remote System Temperature Sensor = Display Only

Local / Remote Input (LR) = Closed (Jumper (LR) to (C))

When the Local / Remote Input (LR) is open, Remote Input (C+,C-) is ignored and Remote Sensor & Local SP Mode is active.

Modbus Network

To establish a Modbus network set the following parameters:

Communication Menu:

Protocol = Modbus

Modbus Address = Give each boiler a unique address.

Baud Rate = Set identical to remote system.

Parity = Set identical to remote system.

Connect all boilers using a RJ11 ended telephone cable.

If the Modbus network is activated the remote system may monitor and/or control boiler operation. Refer to page 26 for additional information.

Product Features

Manual Boiler Control Mode

Display Shows: Manual Operation Mode and Lost Sensor Blind Mode

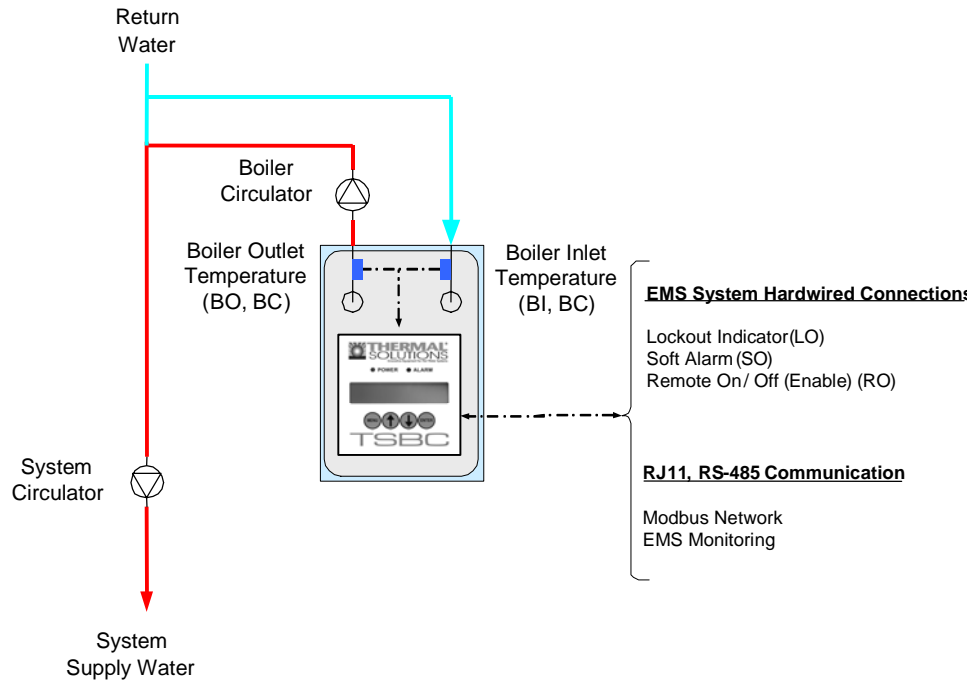

Manual Operation Mode and Lost Sensor Blind Mode Application Diagram
(Showing relevant connections)

MANUAL OPERATION MODE

Features

Modulation Rate Control

The operator sets the modulation rate. The setpoint is ignored.

Call for Heat

The Call For Heat Relay (CH) is directly controlled by the operator. The on and off points are ignored. The boiler will turn off if the water temperature increases past the temperature set on the High Temperature Stop parameter.

Options

Outside Air Reset, Warm Weather Shutdown and Domestic Hot Water Priority are ignored.

The Spare Output (VI) and Combustion Air Damper (SO) outputs are energized when the operator starts the boiler in manual mode.

Selecting This Control Mode

Manual Mode is activated from the Manual Mode menu when Supervisor password is entered. Simply set the Boiler Man/Auto parameter to "Man" and adjust the Modulation Rate and Boiler On/Off menu items as required. Once activated the green LED flashes. To leave manual mode set the Boiler Man/Auto parameter to "Auto".

LOST SENSOR BLIND MODE

If both Remote System Temperature (RST) and boiler outlet temperature and the Remote Control input signal (C,-C+) have failed, the boiler is started and run continuously at the lowest modulation rate.

If the controller has entered Lost Sensor Blind Mode, the user may switch the boiler into manual mode or repair, replace or reconnect required temperature sensors.

Product Features

Auxiliary Device Control

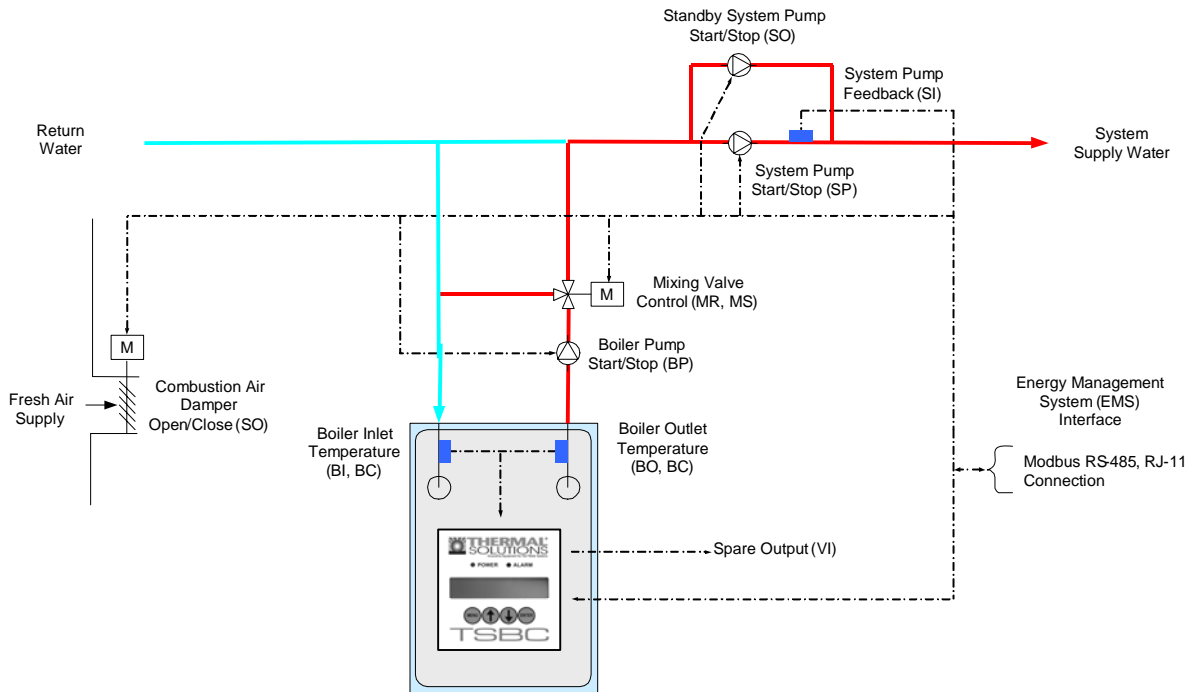

Auxiliary Control Application Diagram
(Showing All Options)

Features

Mixing Valve

The primary function of the mixing valve is to protect the boiler from thermal shock and sustained flue gas condensation. When configured, the mixing valve output compares both minimum return water temperature setpoint to measured return water temperature and boiler differential temperature setpoint to measured differential temperature (boiler outlet minus inlet temperature).

If the boiler return water temperature drops below the minimum inlet water temperature setpoint (“Min In H2O Temp” parameter) or the differential temperature increases above the maximum water differential temperature setpoint (“Max H2O Delta T” parameter) the mixing valve opens to allow hot boiler outlet water to blend with cold return water. The valve repositions toward 0% recirculation after return water increases above setpoint and the differential temperature reduces below setpoint.

The mixing valve may be controlled manually from the Manual Mode menu when Supervisor password is entered. Simply set the Mixing Valve M/A parameter to “Man” and adjust the Mixing Valve % as required. Once activated the green LED flashes. To leave manual mode set the Mixing Valve M/A parameter to “Auto”.

Combustion Air Damper and Vent Inducer

When the Relay (CH) is closed, the Combustion Air Damper (CAD) and Vent Inducer outputs are energized. If the CAD open position is needed to be proven, a limit switch may be wired in series with the Low Water Cut-off Switch input (LC). The alarm Message may be modified to reflect this change.

Boiler Pump

The Boiler Pump output (BP) may be configured as None, Always On, Purge or Lead On by setting the Boiler Pump (parameter 2) (refer to page 28):

- Always On: Boiler pump runs continuously.
- Purge: Boiler pump runs during a pump Prepurge [Pump Prepurge (parameter 3) time before boiler starts], while the boiler is running and during a pump cooldown period. [Pump cooldown maintains the boiler pump running until the boiler outlet temperature is within the Postpurge Delta (parameter 4) degrees above the boiler inlet temperature.]
- Lead On: Boiler Pump runs continuously when the boiler is the lead and during the fan pre-purge, while the boiler is running and during fan post purge when a lag boiler.

The boiler pump sequences are detailed on the boiler sequence diagram on page 6.

System and Standby System Pump

When configured, the System Pump output (SP) is always energized except when turned off by the Warm Weather Shutdown feature. A Standby System Pump output (SO) may be configured as a backup to the system pump. The Standby System Pump is started based on the System Pump Feedback input (SI).

Selecting This Control Mode

These control modes may be selected using the Boiler and System Configuration menus.

Front Panel

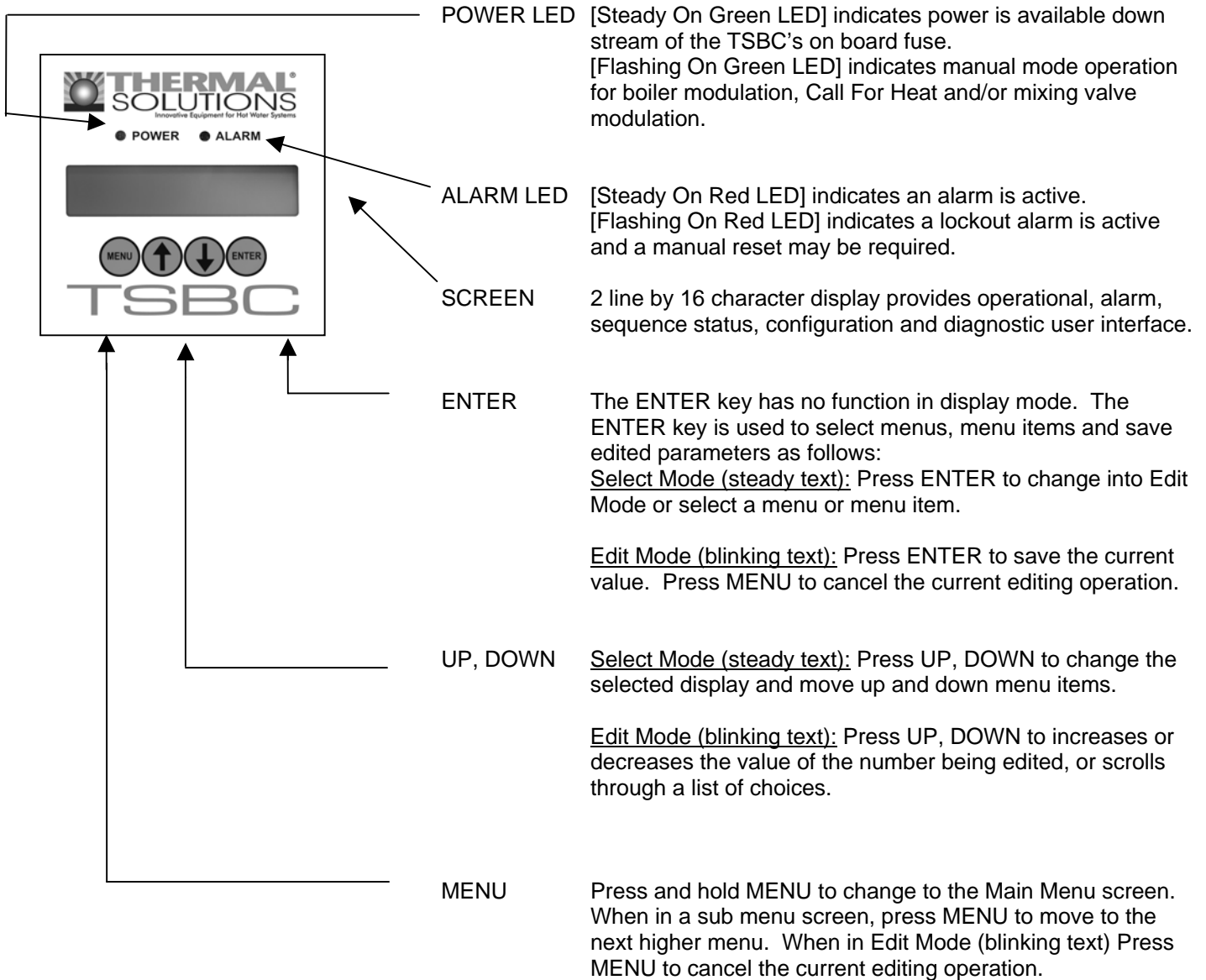

Features



Front Panel

Display Mode

All values shown in Display Mode are for display only and can not be adjusted by the operator. The

  keys scroll through the Display Mode screens:

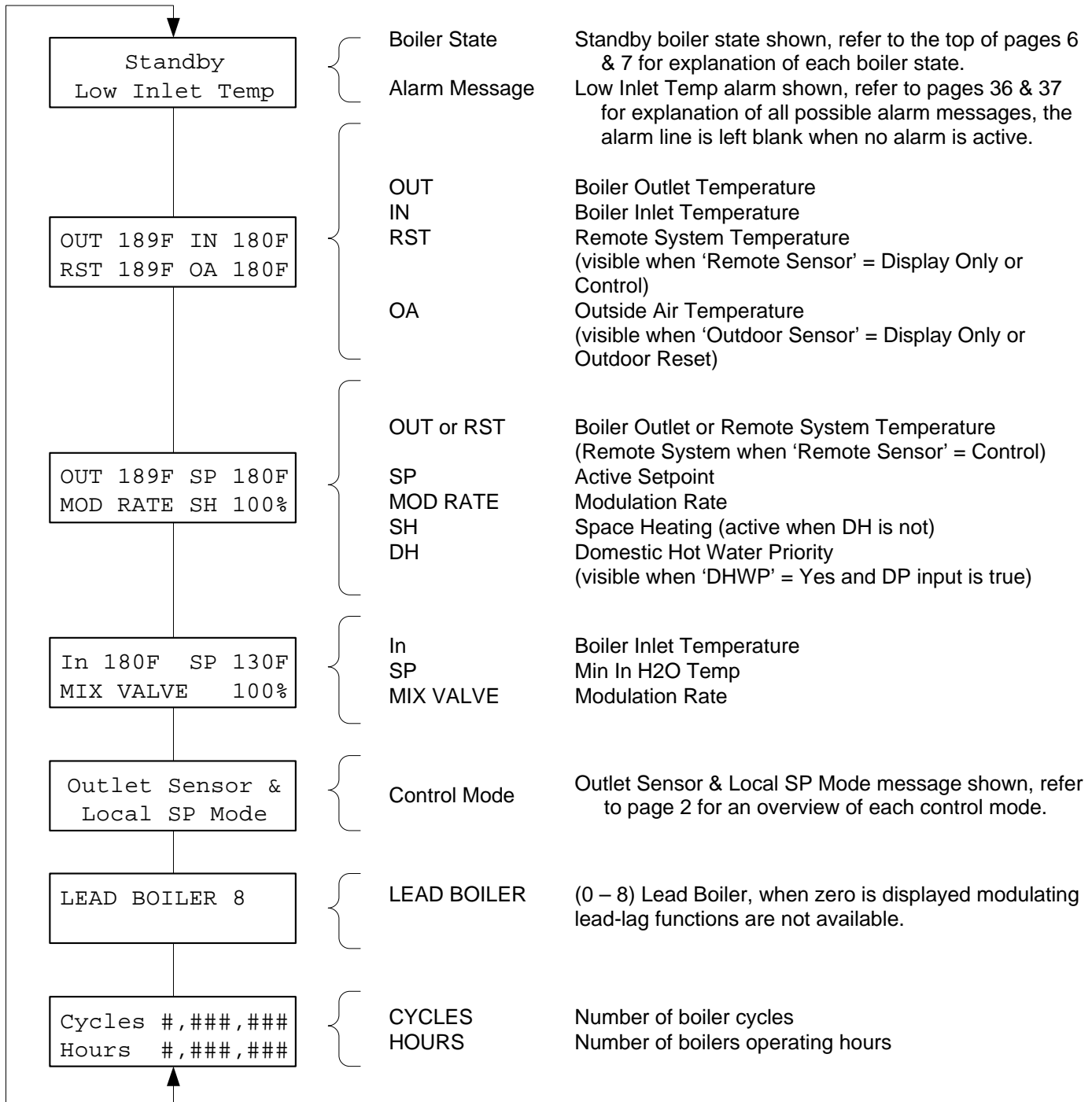

Home Screen

The Boiler State and Alarm Message screen is the 'Home Screen' and is reverted to when no key has been selected for longer than 30 minutes.

Alarm LED

New alarms illuminate the alarm LED and energize an alarm output (SO) (if enabled). If a lockout condition is detected, the alarm LED will blink and the lockout indication output (LI) is energized. The display Message is cleared and relays de-energize when the alarm condition is cleared.

Front Panel

Display Navigation

Press and hold the  key to leave the Display Mode and access the Main Menu:

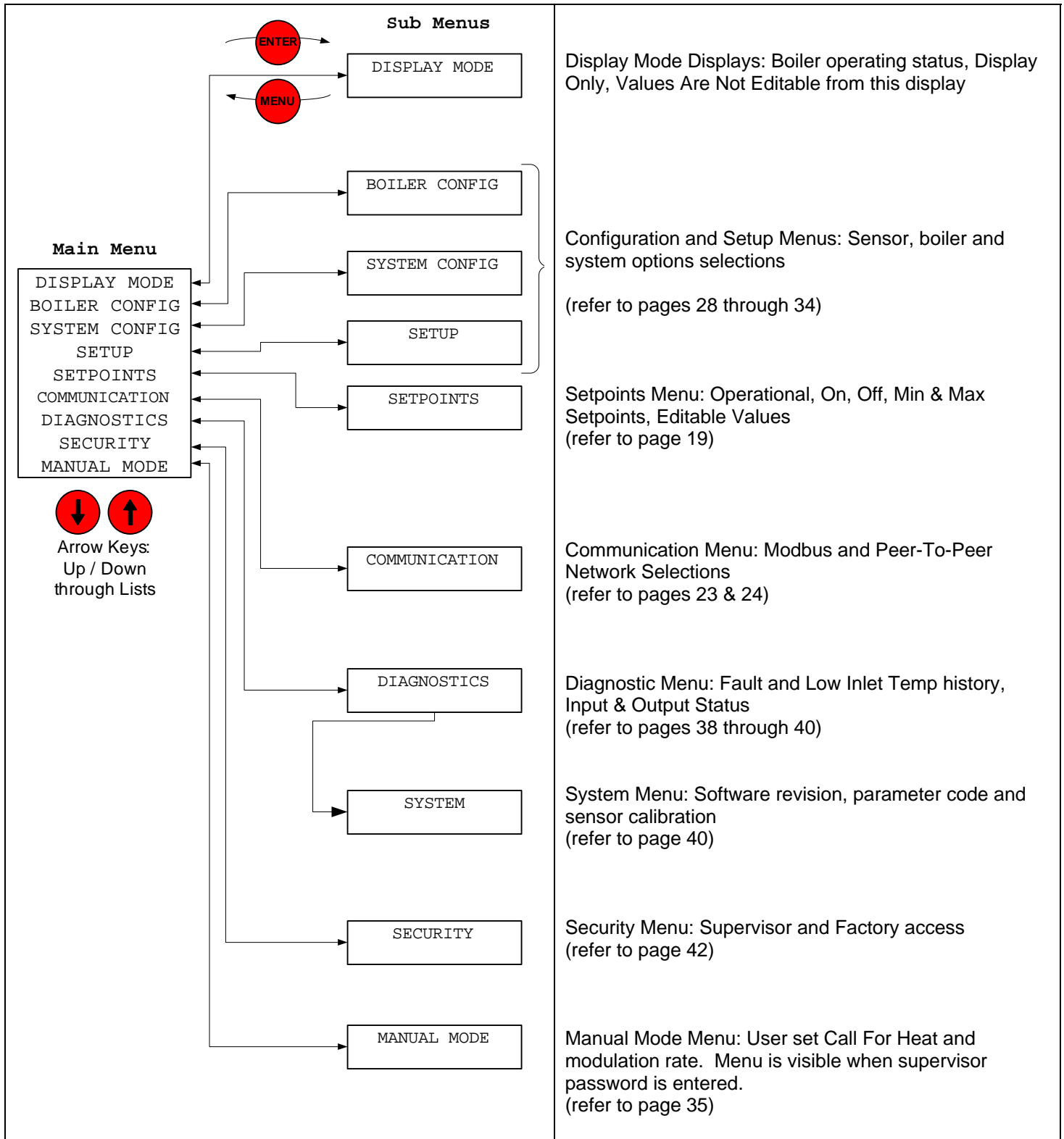

Front Panel Setpoint Menu

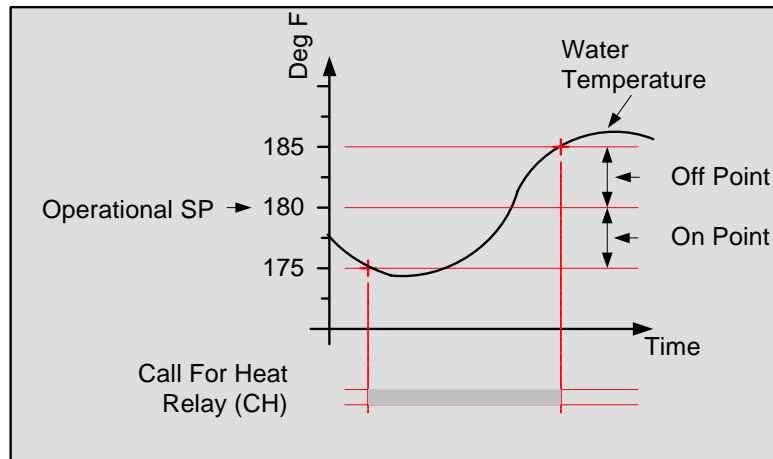

Call For Heat Settings

No.	Range / Choices	Parameter and Description
70	60 F to 230 F	Operational Setpoint Setpoint used in Local Setpoint Mode when not servicing a Domestic Hot Water Priority (DHWP) request.
71	0 F to -99 F	On Point The boiler starts when the water temperature drops 'On Point' degrees below the setpoint.
72	0 F to 99 F	Off Point The boiler stops when the water temperature rises 'Off Point' degrees above the setpoint.
73	60 F to 230 F	High Temp Stop The boiler stops when the boiler outlet water temperature is above the High Temperature Stop setpoint. This setpoint is active in every control mode. If the lead boiler's boiler outlet temperature is above the high temperature stop all boilers are stopped.
74	140 F to 230 F	*DHWP Setpoint The Domestic Hot Water Priority (DHWP) Setpoint is active when DHWP Input (DP) closes and "DHWP" parameter is set to "yes" and Local SP Mode is selected. When the contact is closed, the boiler outlet is maintained at, or above, the DHW Setpoint.
75	40 to 90 F	*WWSD Setpoint The Warm Weather Shutdown (WWSD) Setpoint used to disable boiler and or system pump operation when enabled by setting the "WWSD" parameter to "WWSD of Boiler", "WWSD of Sys Pump" or "Both".
76	140 F to 230 F	Max SP The Maximum Operational Setpoint for all possible Local and Remote modes.
77	60 F to 230 F	Min SP The Minimum Operational Setpoint is the lower limit for all Local and Remote modes.
78	110 F to 235 F	Min BIT Low Boiler Inlet Temperature alarm and event setpoint.
79	110 F to 180 F	*Min In H2O Temp. Minimum Inlet Water Temperature setpoint used as the Mixing Valve inlet temperature setpoint.
80	20 F to 50 F	*Max H2O Delta T Maximum Water Differential (Boiler Outlet minus Boiler Inlet) Temperature setpoint used as the Mixing Valve differential temperature setpoint.
81	20 F to 50 F	Max Delta T Hold Maximum Water Differential (Boiler Outlet minus Boiler Inlet) Temperature used to hold modulation rate at low fire.

* Only visible when parameter enabled on the configuration and setup menus

Installation

Terminal Layout

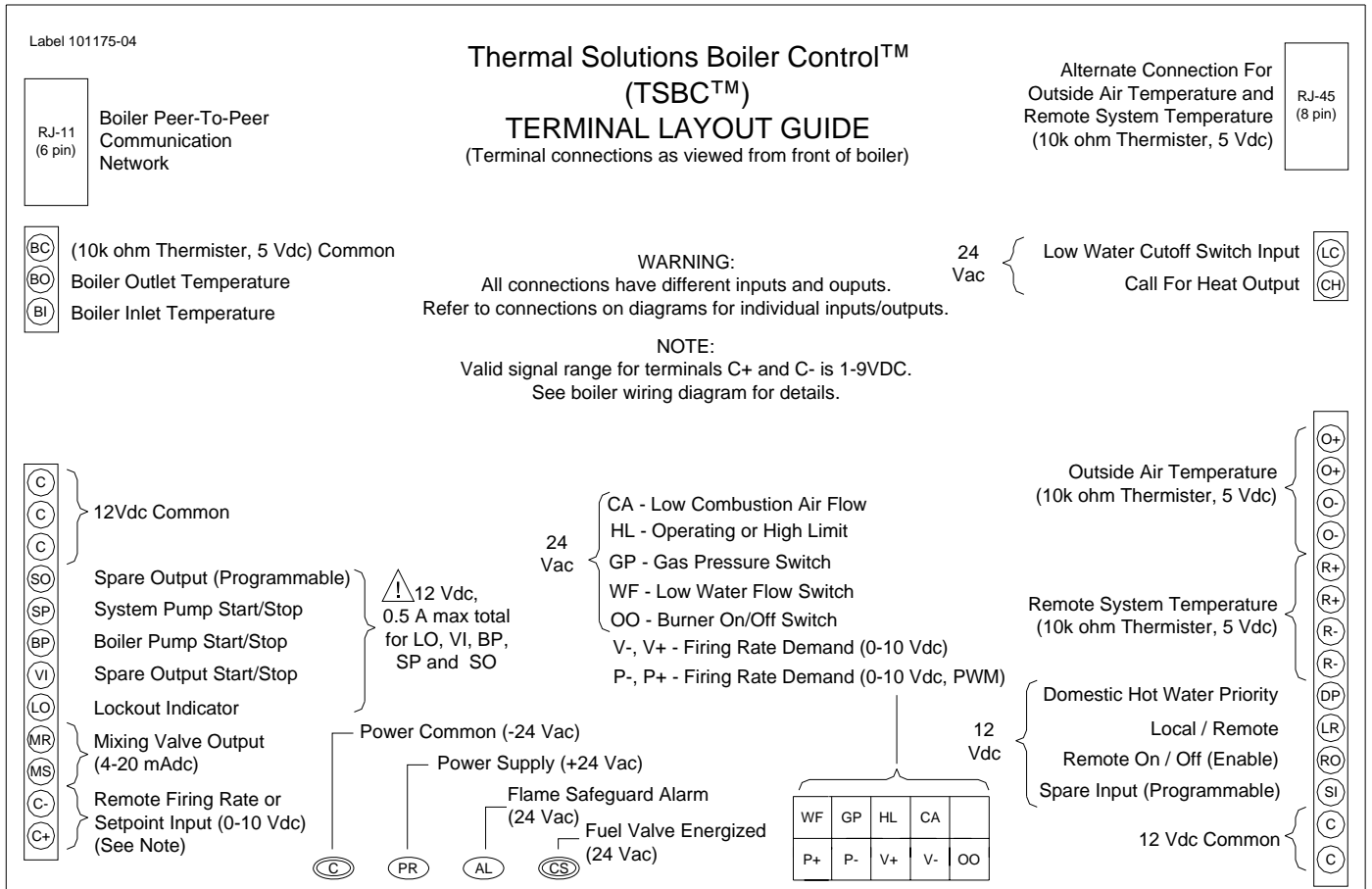

TSBC Terminal Layout Guide

Installation

External Connections

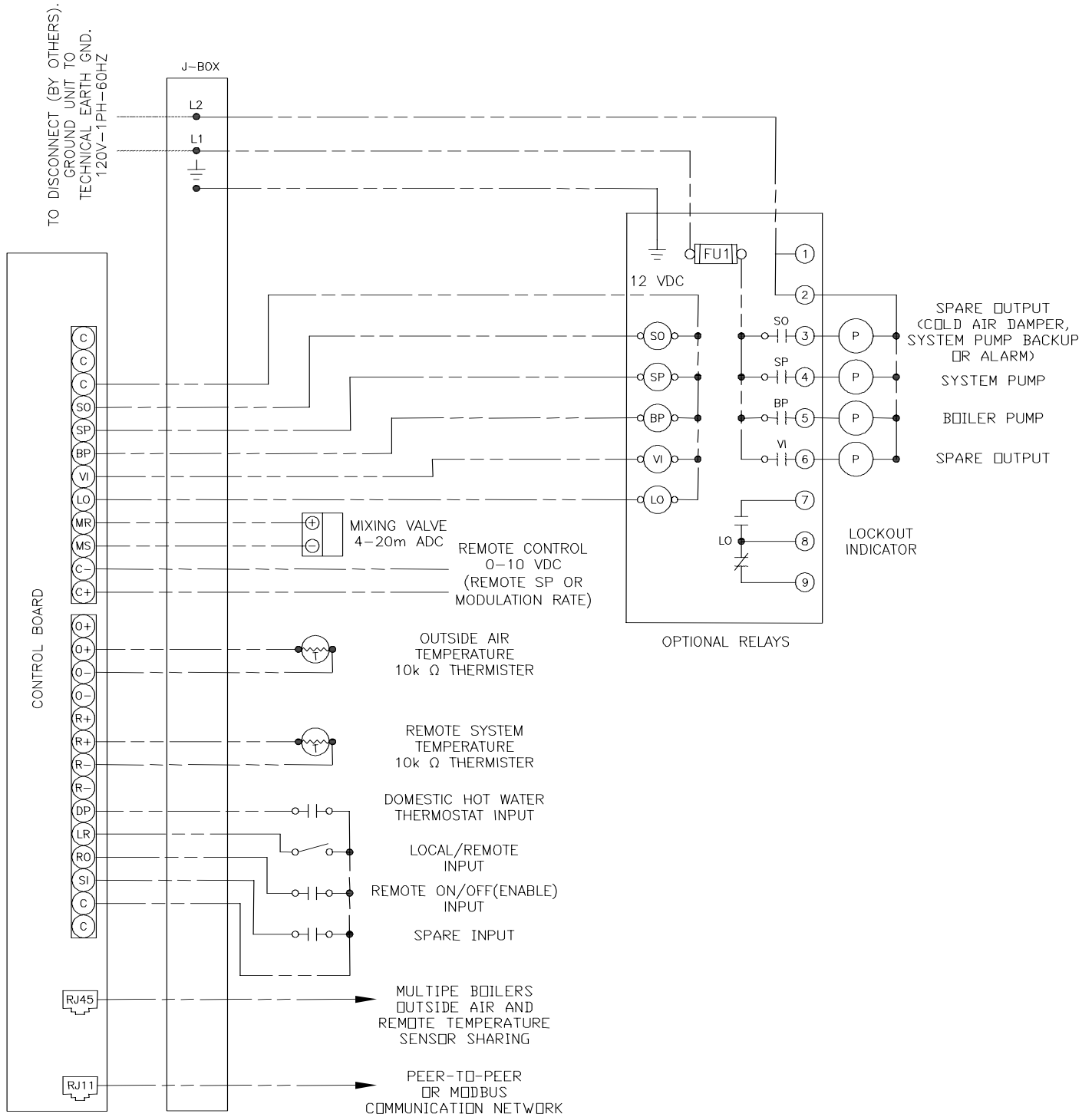

System Water Temperature Sensor

Mount the sensor in the common header downstream of all boiler connections. Locate the sensor a minimum distance of 10 straight pipe diameters from the flow disturbing fittings.

Outdoor Air Temperature Sensor

Mount the temperature sensor on an outside wall out of direct sunlight, preferably on a north facing wall. Do not mount sensor near exhaust of any kind, as this may affect readings.

Installation

External Connections (Continued)

Outside Air and Remote System Temperature Sensor RJ45 Connection

All boilers may be connected to the remote system temperature (RST) and the outdoor air temperature (OAT) sensors. Only one of each type sensor is needed for connections with up to eight boilers. The lead boiler is automatically enabled to monitor the sensors. As the boiler lead rotates the sensor monitoring is automatically transferred to the new lead boiler.

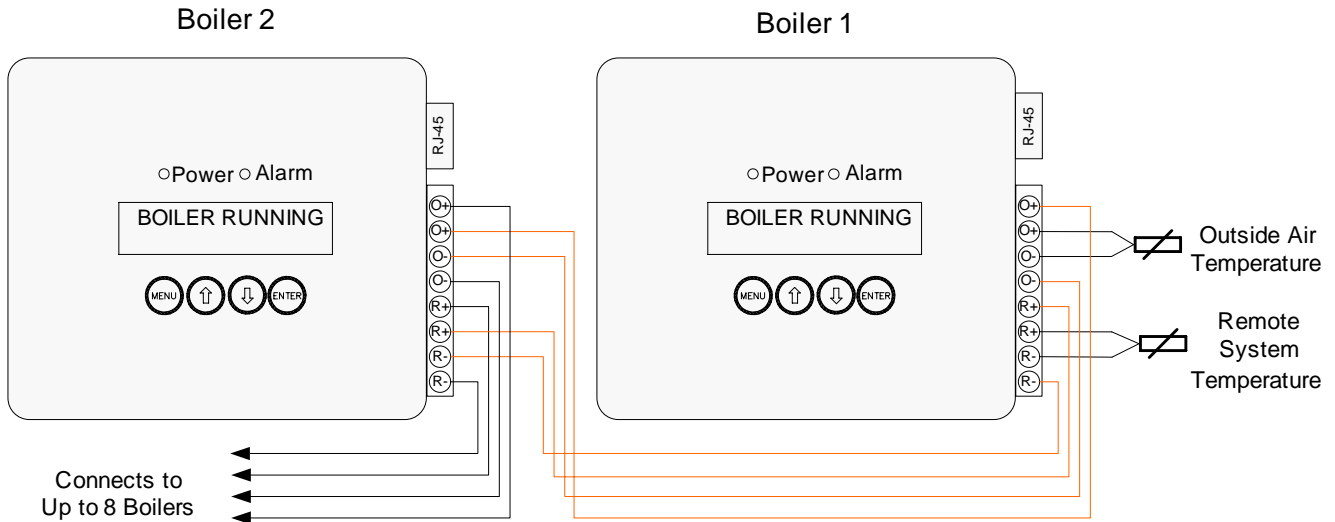

Multiple Boiler Connection Diagram
(Using the extra O+, O-, R+ & R- terminals to daisy chain the boilers together)

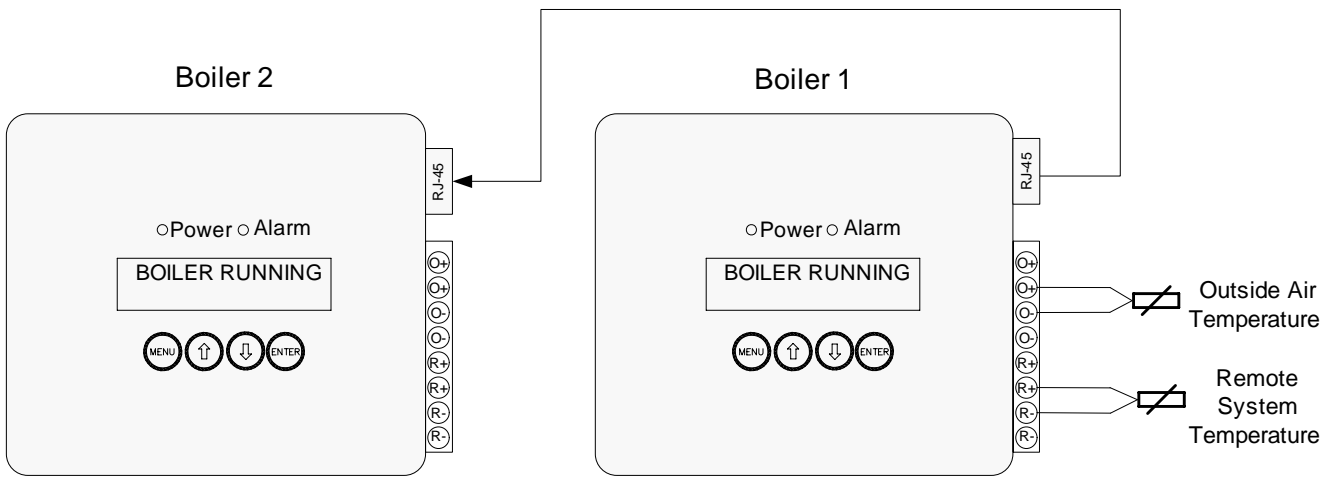

Two Boiler
RJ45 Connection Diagram
(Refer to Note 2)

Notes

1. Used Only For Peer-To-Peer Network. When using Modbus Network wire Outside Air and Remote System sensor to only one boiler.
2. Wiring from the Outside Air and Remote System Temperature sensors should use low impedance, shielded, twisted pair wire and go directly to the terminals on any one boiler. Signal wiring should not be run in the same conduit with power wiring. Wire shields may be connected to the common terminal (C) located on the same terminal block with the outside air and remote system temperature connections.
3. The RJ45 sensor cables need to be a straight through type cable that connects each pin of the connector on one end to it's identical pin on the opposite end. Up to a total of three boilers may be connected using a RJ45 splitter. When connecting more than three boilers, it is recommended, and may be more convenient, to use the extra O+, O-, R+ & R- terminals to daisy chain the boilers together (eliminating the need for RJ45 cables and splitters and reducing the loop impedance).

Installation Communication

The Peer-To-Peer or Modbus networks allow boiler information, including modulation rate and on/off commands, to be sent via a standard phone cable thus avoiding the cost, time and complexity of wiring multiple signals.

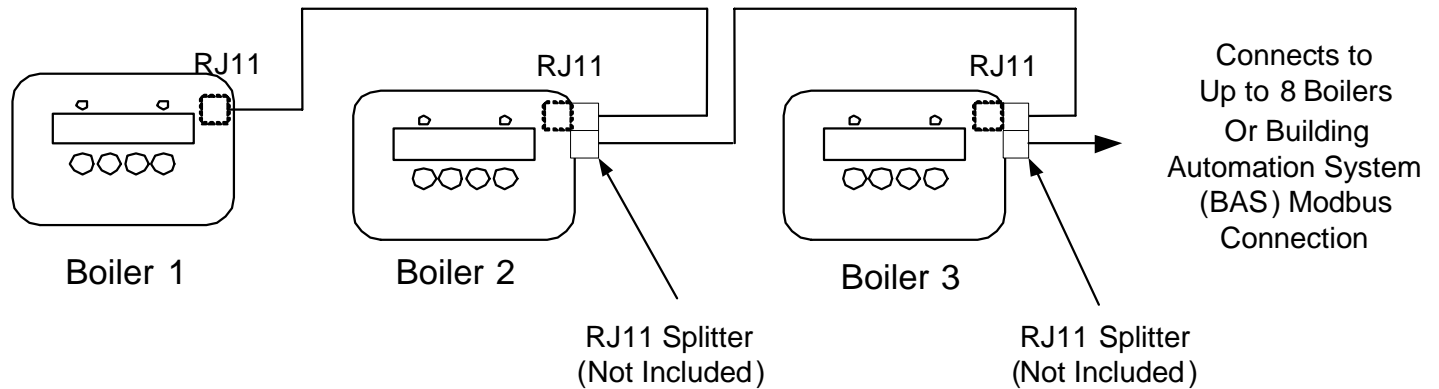

Multiple Boiler
RJ11 Connection Diagram

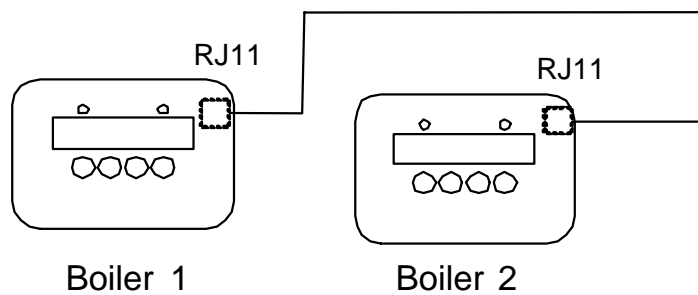

Two Boiler
RJ11 Connection Diagram

When Wiring Modbus Communication to a Building Automation System (BAS)

The Modbus communication connects to the same RJ11 port that is used by the peer-to-peer communication. Connect one end of the RJ11 cable to the TSBC and cut off the other end of the cable to access the individual conductors. The TSBC is a 2 wire Modbus communication. Connect the "A" and "B" terminals of a four wire or six wire phone cable (as shown below) to the BAS terminals. The TSBC includes two sets of A and B connections, where the A represents the active transmission state of the RS485 transmitter (as opposed to the line idle state). You need only to wire to one of the "A" terminals and one of the "B" terminals.

Phone cable signals (4 wire) - connect to pin black or yellow and red or green:

Wire Color	Slot Number	Connection
Black	1	A
Red	2	B
Green	3	B
Yellow	4	A

Notes

1. Use standard phone cables (although ones that have all six wires terminated at each end) and splitters to connect each boiler.
2. Please note that all connections between boilers must be kept as short as possible. The maximum cable length between boilers must be kept under 25 feet (average distance between all boilers).
3. In all cases, the wires should be routed away from any obvious sources of electrical noise or magnetic fields (motors, fluorescent lights, contactors, spark generators, etc.). Use a separate conduit and junction box from the power wiring.
4. TSBC power supply common must be grounded at each boiler to enable network communication.

Installation

Communication (Continued)

The TSBC communication selections are found on the Communication Menu. Press and hold the key to leave the Display Mode and access the Main Menu:



Use the   keys scroll down to the Communication Menu and push the  key:

Communication Menu

No.	Range / Choices	Parameter and Description
90	Peer to Peer Modbus	Protocol Selects between Peer-To-Peer (multiple boiler Lead/Lag control network) and a Modbus slave communication.
91	1-247	Modbus Address Each boiler must be given a unique address. Only visible when <i>Protocol</i> equals Modbus.
92	9.6 19.2 38.4	Baud Rate Units are 1000 Bits Per Second (KBPS). Only visible when <i>Protocol</i> equals Modbus.
93	Odd Even None	Parity Only visible when <i>Protocol</i> equals Modbus.
94	1-120 Seconds	Timeout Only visible when <i>Protocol</i> equals Modbus.
95		Messages Rcvd Diagnostic tool used to confirm wiring and Modbus master configuration. Only visible when <i>Protocol</i> equals Modbus.
96		Messages Sent Diagnostic tool used to confirm wiring and Modbus master configuration. Only visible when <i>Protocol</i> equals Modbus.
97	1 to 8	Boiler Address Each boiler must be given a unique address. The boiler address assignment determines the boiler sequencing order. A value of 0 disables the network communications. Only visible when <i>Protocol</i> equals Peer to Peer.
98	-- 6 --- 321	Online Status Each space can be either the boiler address or a ' - ' depending on whether there is a boiler of that address on-line. Only visible when <i>Protocol</i> equals Peer to Peer. Example: - - 6 - - - 321 indicates that boilers 6,3,2 and 1 are online

Installation

Peer-To-Peer Network

The TSBC includes a dependable Peer-To-Peer communication network. This network allows multiple boiler modulating lead/lag control and status signals to be transferred between boilers. In order to successful use this network certain requirements must be followed.

Network Relevant & Updated Parameters

When using the Peer-To-Peer network certain "Network Relevant" parameters must be configured the same in all boilers (refer to Appendix B for parameter identification). To facilitate the configuration of these "Network Relevant" parameters, a network update feature has been included. Once communications is established between all boilers in a system, changing to a "Network Relevant" parameter at the keypad of any boiler will update that parameter in all boilers. In addition to the "Network Relevant" parameters, other common parameters are also "Updated" over the network (although it is not necessary for them to be set identically among boilers on the network). If you wish to configure them differently among boilers, you will have to disconnect the boiler from the network while you change them to prevent the other boiler from being changed as well. "Network Relevant" and additional "Updated" parameters are identified in Appendix B, Parameter Summary.

Initially Establishing Peer-to-Peer Communication

A Peer-to-Peer network is established as follows:

1. Assign all boilers a unique Boiler Address between 1 and 8 and set the Protocol to Peer-to-Peer.
2. Connect all boilers using a RJ11 ended telephone cable.
3. Configure all "Network Relevant" parameters identically on all boilers. Unexpected boiler behavior may result if these parameter values differ among boilers on the network. When "Network Relevant" parameters are identical the 'Param Code' parameter will be identical on each boiler (refer to page 40 for parameter location).
4. When two or more boilers are properly configured for communication, the controllers "auto detect" each other and shares information.

Re-Establishing Peer-to-Peer Communication After an Individual Boiler Communication Failure

A Peer-to-Peer network is re-established as follows:

1. Ensure Boiler address is between 1 and 8 and is unique.
2. Ensure the Protocol parameter is set to Peer-to-Peer.
3. Use the 'Param Code' parameter to check that "Network Relevant" parameters are configured identically (refer to page 40 for parameter location).
4. Remove control power from the boiler.
5. Connect the boiler to the network using a RJ11 ended telephone cable.
6. Apply control power to the boiler.
7. The network will "auto detect" the new boiler and assign it a position in the sequence based on the boiler address.

When a boiler is operated as a stand alone boiler, away from the network, it establishes itself as a lead boiler. If this stand alone boiler is simply re-connecting to a network of operating boilers there is a potential that boiler operation will be disrupted as the new boiler becomes lead. This potential is avoided by following the above Re-Establishing procedure.

Installation

RS485 Modbus Network

The TSBC includes a dependable Modbus communication network. This network allows boilers to be controlled and/or monitored by a remote system via a RS485 Modbus communication network. Each TSBC is a Modbus slave with the following available boiler information:

Modbus Addresses

Coil Address	Description	Read/Write	coil = 0	coil = 1	Notes
00001	Outdoor Air Reset Enable/Disable		Disable	Enable	
00002	Domestic Hot Water Priority (DHWP)		Disable	Enable	
00003	Local / Remote		Local	Remote	
00004	Remote On / Off Modbus Command	Y	Off	On	1
00005	Spare Input (Programmable)		Off	On	
00006	Low Water Cutoff Switch		Off	On	2
00007	Burner On / Off Switch		Off	On	2
00008	Low Water Flow		Off	On	2
00009	High and Low Gas Pressure Switches		Off	On	2
00010	Operating or High Limit		Off	On	2
00011	Low Combustion Air Flow		Off	On	2
00012	Fuel Valve Energized		Off	On	
00013	Flame Safeguard Alarm		Off	On	
00014	Call For Heat (CFH)		Off	On	
00015	General Alarm		Off	On	4
00016	Vent Inducer		Off	On	
00017	Boiler Pump		Off	On	
00018	System Pump		Off	On	
00019	Spare Output (Programmable)		Off	On	
00020	State Boiler Disabled		Off	On	3
00021	State Weather Shutdown		Off	On	3
00022	State Lockout		Off	On	3
00023	State Pump Purge		Off	On	3
00024	State Limit Hold		Off	On	3
00025	State Purge/Pilot Ign		Off	On	3
00026	State Low Fire/Ignition		Off	On	3
00027	State Main Ignition		Off	On	3
00028	State Low Fire Hold		Off	On	3
00029	State Boiler Running		Off	On	3
00030	State Fan Post Purge		Off	On	3
00031	State Pump Cool Down		Off	On	3
00032	State Standby		Off	On	3
00033	Annunciator Low Water Level		Off	On	4
00034	Annunciator Off Switch		Off	On	4
00035	Annunciator Low Water Flow		Off	On	4
00036	Annunciator Fuel Limit		Off	On	4
00037	Annunciator High Temp Limit		Off	On	4
00038	Annunciator Low Air Flow		Off	On	4
00039	Annunciator FSG Lockout		Off	On	4
00040	Annunciator Outlet Temp Fail		Off	On	4
00041	Annunciator Inlet Temp Fail		Off	On	4
00042	Annunciator OA Temp Fail		Off	On	4

Installation

RS485 Modbus Network

Modbus Addresses (continued)

Coil Address	Description	Read/Write	coil = 0	coil = 1	Notes
00043	Annunciator Remote Temp Fail		Off	On	4
00044	Annunciator Remote In Fail		Off	On	4
00045	Annunciator Comm Fail		Off	On	4
00046	Annunciator Low Inlet Temp		Off	On	4
00047	Annunciator Memory Failure		Off	On	4

Modbus Register Address	Description	Read/Write	Engineering Units for Register = 0	Engineering Units for Register = 100	Units	Notes
40001	Boiler Outlet Water Temperature		-50	300	F	
40002	Boiler Inlet Water Temperature		-50	300	F	
40003	Outside Air Temperature		-50	300	F	
40004	Boiler Actual Setpoint		60	230	F	
40005	Remote System Temperature		-50	300	F	
40006	Remote Firing Rate or Remote Setpoint	Y	0	100 or 300	% or F	1
40007	PCB Temperature Sensor		-50	300	F	
40008	Firing Rate Output to Mod Motor		0	100	%	
40009	Minimum Return Temperature Setpoint		110	180	F	
40010	Mixing Valve Output		0	100	%	
40011	Control Mode		1	7		

Notes

1. After a Modbus communication failure, while using the Modbus connection to monitor or control the boilers, the 'Comm Failure' alarm is not cleared until a successful write to both the Remote On / Off Modbus Command (00004) and Remote Firing Rate or Remote Setpoint (40006) points have been completed, power is cycled or the 'Protocol' parameter is changed from Modbus to Peer-to-Peer and back again.
2. The limit string points (00006 - 00011) are only monitored when there is a Call For Heat. Additionally, if one of these items is 'open' items down stream are not monitored.
3. The boiler "state" points (00020 - 00032) are mutually exclusive (i.e. only one is asserted at a time). This will reflect the state of the message on the front of the boiler. Refer to page 6 for an explanation of each state.
4. The "Annunciated" points (00033 – 00046) reflect the state of the signals used to control the displayed Alarm Message. Refer to pages 36 & 37 for an explanation of each annunciator point.
5. "General Alarm" point (00015) turns "On" when the boiler is indicating any alarm condition.

To establish a Modbus network set the following parameters:

Communication Menu:



- Protocol = Modbus
- Modbus Address = Give each boiler a unique address.
- Baud Rate = Set identical to remote system.
- Parity = Set identical to remote system.

Connect all boilers using a RJ11 ended telephone cable.

Configuration & Tuning

Boiler Configuration Menu

Boiler operating behavior is adjusted using the configuration & tuning menus. Press and hold the  key to leave the Display Mode and access the Main Menu.

Use the   keys scroll down to the required Menu and push the  key.

No.	Range / Choices	Parameter and Description
1	Deg F Deg C	Display Units Selects how temperature parameter values are displayed.
2	None On Always Purge Lead On	Boiler Pump Activates the boiler pump output according to selected function. None: No Boiler Pump. On Always: Pump Runs Continuously. Purge: Pump Runs during pump pre/post purge operations and during call for heat. Lead On: Pump runs continuously when the boiler is the lead and runs during the fan pre-purge, while the boiler is running and during fan post purge when a lag boiler.
3	0 to 600 Seconds	Pump Prepurge Sets length of time the boiler pump will be run prior to closing the "Call for Heat" relay (CH).
4	0 to 20 C or F	Postpurge Delta Sets the temperature above boiler inlet temperature that boiler outlet temperature must be below before turning off the boiler pump during pump post purge (Pump Cooldown State).
5	No Yes	Mixing Valve Enables the mixing valve control output and user display.
6	No Yes	Inlet Sensor (Return Sensor) Enables the return temperature display and control logic.
7	hour : minute month / day / year	Set Time/Date Displays and sets the time and date of the boiler's real time clock.
8	No Yes	Fuel Limit Specifies a Fuel Limit such as high and low fuel gas pressure switches are connected to input (GP). Enables Fuel Limit Hold and alarm messages.
9	Off Sys Pump Feedback Low Fire	Spare Input Sets the function of the Spare Input Terminal (SI): Off: Ignore. Sys Pump Feedback: Input (SI) should be wired to a flow switch inserted in the flow path of the system pump. Input (SI) indicates the system pump is operating. If output (SO) is set to System Backup Pump, system pump output (SO) is energized and System pump Feedback is de-energized the System Backup Pump output (SO) is energized. Low Fire: When the Fuel Valve Energized input (CS) is not energized and Input (SI) is energized the modulation rate is set to the "Low Fire" setpoint. When input (SI) is not energized, the modulation rate is set to "Fan Purge" setpoint. When the fuel valve energized input (CS) is energized input (SI) is ignored.
10	Off CAD System Pump BU Soft Alarm	Spare Output Sets the function of the Spare Output Terminal (SO): Off: Never close output (SO). CAD: Combustion Air Damper (CAD) or fresh air damper Closes SO relay with a call for heat, Opens SO relay 2 minutes after call for heat has been de-activated. System Pump BU: Closes when System Pump output is activated but the System Pump Feedback indicates the Primary System Pump is not operating. Soft Alarm: Alarm indication or warning, closes when any alarm is active, or a condition is preventing a boiler start, including Off Switch.

Configuration & Tuning

System Configuration Menu

No.	Range / Choices	Parameter and Description
20	Off Isolated Demand Shared Demand	<p>DHWP Enables Domestic Hot Water Priority (DHWP) control feature. When input (DP) is energized DHWP becomes active as selected:</p> <p>Off No DHWP.</p> <p>Isolated Demand Boiler that receives the input (DP) drops off the Peer-To-Peer network and it's temperature setpoint is adjusted above the DHWP Setpoint. The PID output is based on boiler outlet temperature and setpoint. If Remote SP or Remote System temperature sensors were selected, control is switched to the Boiler Outlet Sensor.</p> <p>Shared Demand If the lead boiler receives the input (DP) the temperature setpoint for all boilers on the Peer-To-Peer network is adjusted above the DHWP Setpoint.</p>
21	No Remote SP Modbus SP Remote Mod Modbus Mod	<p>Remote Control Sets the remote (Energy Management System) control mode as follows:</p> <p>No: Local setpoint and modulation rate is used. Modbus and remote input (C+,C-) are ignored.</p> <p>Remote SP: Remote Input (C+, C-) is used as the temperature setpoint. Parameter 22 & 23 may be used to adjust the signal range.</p> <p>Modbus SP: RS485 Modbus (40006) is used as the temperature setpoint.</p> <p>Remote Mod: Remote Input (C+, C-) is used as the modulation rate.</p> <p>Modbus Mod: RS485 Modbus (40006) is used as the modulation rate.</p>
22	60 F to 140 F	<p>Remote 1.0 Volt= Sets the temperature corresponding to input (C+,C-) 1Volts. Voltage below 1V is considered invalid, (failed or incorrect wired sensor).</p>
23	150 F to 220 F	<p>Remote 9.0 Volt= Sets the temperature corresponding to input (C+,C-) 9 Volts. Voltage above 9V is considered invalid, (failed or incorrect wired sensor).</p>
24	No Display Only Control	<p>Remote Sensor Enables the Remote System Temperature sensor display and control logic:</p> <p>No Remote Sensor Input (R+,R-) is ignored.</p> <p>Display Only Remote Sensor Input (R+,R-) is used for display only.</p> <p>Control Remote Sensor Input (R+,R-) is compared with the temperature setpoint to establish a modulation rate.</p>
25	No Yes	<p>System Pump Enables the System Pump output (SP).</p>
27	No Yes	<p>LWC or CAD Specifies a Low Water Cut-off Switch or Combustion Air Damper (Fresh Air Damper) Open switch is connected to input (LC). Enables Limit Hold and alarm messages. Limit hold display message is described by parameter 28.</p>
28	16 Text Characters	<p>Alarm Message Limit Hold and alarm message displayed corresponding to sensor connected to input (LC).</p> <p>The "ENTER" key and "Up" and "Down" arrow keys are used to change the text Message.</p>

Configuration & Tuning Setup Menu

No.	Range / Choices	Parameter and Description
30	Off WWSD of Boiler WWSD of Sys Pump Both	<p>WWSD Specifies Warm Weather Shut-Down (WWSD) control of boiler and/or system pump:</p> <p>Off: Ignores Warm Weather setpoint. WWSD of boiler: When Outside Air Temperature (OAT) is higher than the WWSD setpoint, inhibits boiler start. WWSD of Sys Pump: When OAT is higher than the WWSD setpoint de-energize System Pump output (SP). Both: When OAT is higher than the WWSD setpoint, inhibit Call for Heat and de-energized system pump output (SP).</p>
31	50 to 100 % Maximum Modulation Rate	<p>LL Start Trigger Specifies the percent of maximum modulation rate the running boiler(s) must reach before calling upon additional boilers for help.</p>
32	0 to 50 % Modulation Rate	<p>LL Stop Trigger Specifies the modulation rate that the running boiler(s) must be below before shutting down a lag boiler.</p>
33	60 to 900 Seconds	<p>Boiler On Delay Time Delay after On Point setpoint has been reached before starting the next boiler. Short time delay to prevent nuisance starts due to momentary temperature and modulation rate swings.</p>
34	0 to 900 Seconds	<p>Boiler Off Delay Time Delay after the Off Point setpoint before stopping the next boiler. Short time delay to prevent nuisance stops due to momentary temperature and modulation rate swings.</p>
35	1 to 30 Minutes	<p>%FR On Delay Time Delay after the modulation rate is above the LL Start Trigger before starting the next boiler. Long time delay to avoid temperature going below setpoint as a result of a slow process change.</p>
36	1 to 30 Minutes	<p>%FR Off Delay Time Delay after the modulation rate is below the LL Stop Trigger before stopping the next boiler. Long time delay to avoid temperature going above setpoint as a result of a slow process change.</p>
37	40 - 100 % Modulation Rate	<p>High Fire Limit To maximize high efficiency condensing operation, the firing rate is limited to an adjustable value. The TSBC will keep the boilers at this firing rate or lower as long as the boilers will handle the load. After the last boiler has started the modulation rate is released up to 100%.</p>
38	1 - 10 Degrees/Minute	<p>Deg/Min Hold Off Specifies a temperature rate of change that inhibits the next boiler being started or stopped. If the temperature is increasing faster than this rate of change the next boiler is not started. Also, if the temperature is decreasing faster than this rate of change the next boiler is not stopped.</p>
39	100 - 240 C or F	<p>Cutback Setpoint Boiler Outlet temperature above the Cutback Setpoint causes the modulation rate to be reduced proportionally to help avoid a high temperature limit lockout. This parameter is significant while the boiler is controlled according to the remote system temperature sensor or remote input (C+,C-) or Modbus (40006) Remote Firing Rate.</p>

Configuration & Tuning

Setup Menu (Continued)

No.	Range / Choices	Parameter and Description
40	16 to 420 Seconds	Net Start Dwell The Net Start Dwell Time Delay specifies the length of time the peer-to-peer network will wait for the Main Fuel Valve Energized input (CS) to be energized after a boiler Call for Heat. If the Net Start Dwell time is exceeded before the main fuel valve is open the next boiler Call for Heat is initiated without further delay. This parameter should be longer than the sum of the pump purge and boiler purge times.
41	3 to 120 Seconds	Limit Fault Time The Limit Fault Time Delay specifies the length of time the peer-to-peer network will wait for the boiler limits input (CA) to be energized after a boiler Call for Heat. If the Limit Fault time is exceeded before the limits are energized the next boiler Call for Heat is immediately initiated.
42	Disable Enable	Rotation Enables the lead boiler role to be rotated through the boilers on the network. When disabled the boiler with the lowest network address is lead.
43	8-720 Hours	Rotate after Specifies number of hours (cumulative) a lead boiler runs before passing the lead to another boiler. Lead role will be surrendered earlier if the lead boiler is placed into manual mode, is run remotely (mode 6), fails to start, is "blind" (all input sensors failed), or is satisfying a DHWP request. Parameters 44 through 48 are found on the following page.
49	0 to 100 % Full Scale	Blower Spd High (Linkage Max. Position) Percent of (0 - 10 Vdc output [V+,V-]) output that represents a 100% modulation rate. This scaling factor allows the TSBC to display 100 % when the linkage is at rated boiler output. Please Note The Burner input rate adjustment must be completed <u>before</u> this parameter can be set. After maximum boiler firing rate is established, the TSBC Firing Rate Display "FR" percentage should be 100%. If boiler rate is established at less than 100% FR, that value should be entered in parameter 49 as blower speed high. This will establish the correct scaling factor and will prevent overfiring of the boiler.
50	0 to 100 % Full Scale	Blower Spd Low (Linkage Min. Position) Percent (0 - 10 Vdc output (V+,V-) or pulse) output that represents a 0% modulation rate. This scaling factor allows the TSBC to display 0 % when the linkage is at minimum boiler output.
51	0-100 % Modulation Rate	Low Fire Spd Modulation % used for Low Fire Hold and Low Fire Start conditions. Low fire position is established by the linkage adjustment. This parameter may be left at 0%.
52	0 to 100 % Modulation Rate	Fan Purge Speed Modulation % used for Fan Purge condition. Purge position is established by linkage adjustment. This parameter may be left at 100%.
53	10 to 1200 Seconds	Low Fire Hold Time modulation rate is held at preset value (Low Fire Spd or Fan Purge Spd depending on the state and configuration of Spare Input) after the Fuel Valve Energized Input (CS) is energized.
54	0 to 600 Seconds	Post Purge Time Time modulation rate is held at Purge % setpoint after the Fuel Valve Energized Input (CS) is de-energized.

Configuration & Tuning

Setup Menu (Continued)

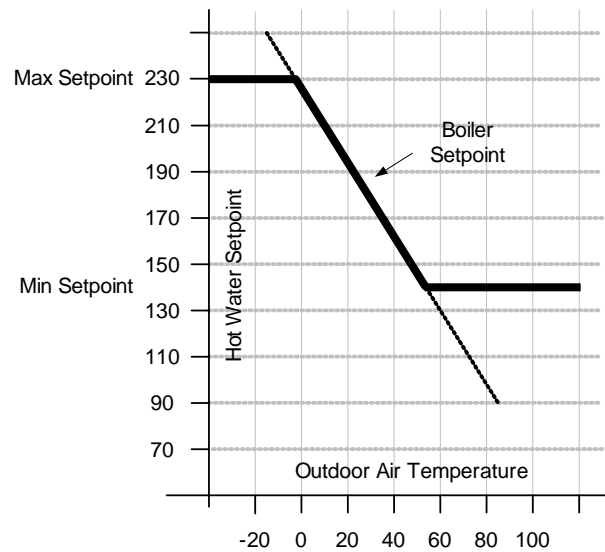
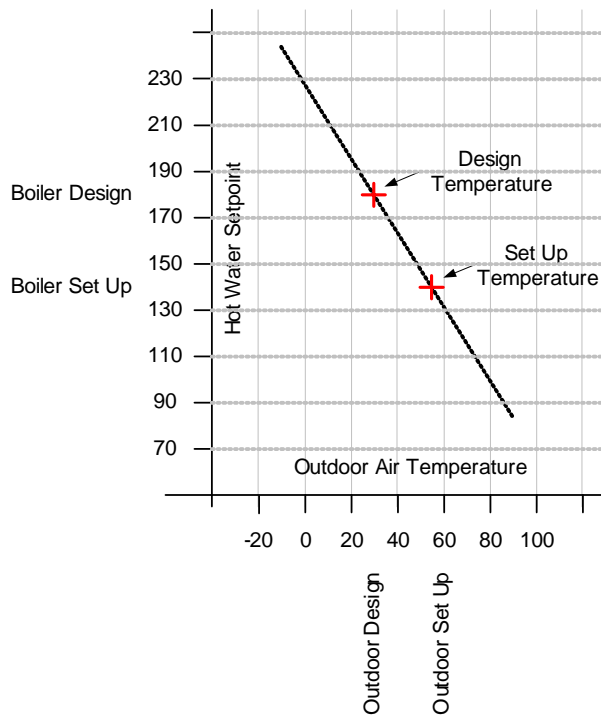

Outdoor Reset Graph

Energy used by the hot water heating system can be greatly reduced by adjusting (resetting) the operating temperature setpoint as the outdoor temperature changes. Using this approach, the heat lost from the building is matched by the heat input to the building. The control utilizes a reset curve to set the relationship between outdoor temperature and boiler outlet temperature setpoint. The reset curve is determined from the “Set Up” and the “Design” conditions as shown in the above graph and described by parameters 45, 46, 47 and 48:

No.	Range / Choices	Parameter and Description
44	No Display Only Outdoor Reset	Outdoor Sensor Enables the Outside Air Temperature display and control logic: No Outside Air Input (O+O-) is ignored. Display Only <u>Do Not</u> Calculate setpoint based on outdoor temperature; Display Outside Air Temperature. Outdoor Reset Calculate the temperature setpoint based on outdoor temperature using a reset curve defined by Outdoor Set Up, Boiler Set Up, Outdoor Design and Boiler Design parameters.
45	40 F to 100 F	Outdoor Set Up The Outdoor Set Up temperature is the outdoor temperature at which the Boiler Set Up temperature is supplied.
46	140 F to 180 F	Boiler Set Up The Boiler Set Up Temperature is the starting boiler water temperature of the reset ratio. If the building feels cool during mild outdoor conditions, the Boiler Set Up setting should be increased.
47	-20 F to 50 F	Outdoor Design The Outdoor Design Temperature is the outdoor temperature at which the Boiler Design temperature is supplied.
48	150 F to 220 F	Boiler Design The Boiler Design setting is the water temperature required to satisfy the building heat loss during the Outdoor Design temperature. If the building feels cool during cold outside conditions, the Boiler Design setting should be increased.

Configuration & Tuning

Setup Menu (Continued)

Slower Response ← **Factory Setting** → Faster Response

PID (P)	PID (I)		
	½ Repeats/Minute	1 Repeats/Minute	2 Repeats/Minute
61	20	10	5
41	30	15	8
36	34	17	9
30	40	20	10
25	48	24	12
20	60	30	15
15	80	40	20
12	100	50	25
10	120	60	30
9	140	70	35
8	160	80	40

Faster Response ↑
Local PID Factory Setting
↓ Slower Response

Typical TSBC PID Gain and Integral Settings

No.	Range / Choices	Parameter and Description
55	0 to 10000	<p>Local PID P Proportional Gain value for boiler outlet temperature sensor control Modes. A larger gain value results in tighter, more active, PID control. Gain is the primary PID modulation rate tuning adjustment and provides the immediate modulation rate response.</p> <p>Pick a gain based on the desired initial response. The burner modulation rate can oscillate if the Proportional Gain is too large.</p>
56	0 to 10000	<p>Local PID I Integral gain value for boiler outlet temperature sensor control Modes. A smaller value makes the Integral ramp in less time (i.e., faster). Integral is a secondary PID modulation rate tuning adjustment that ramps the output over time (typically minutes).</p> <p>Based on the selected Local PID P, select the corresponding (from above table) Integral value. Repeats per minute between 0.5 and 2.0 are typical. The burner modulation rate can oscillate if the Integral time is too small.</p>
57	0 to 10000	<p>Local PID D The Derivative gain value for boiler outlet temperature sensor control Modes. A larger Derivative gain value produces a larger PID output contribution proportional to the rate of change of the error (Setpoint – Boiler Outlet Temperature). When set equal to zero it has no effect on the output.</p>
58	0 to 10000	<p>Remote PID P Proportional Gain value for Remote System Temperature sensor control Modes. Refer to Local PID P for explanation.</p>
59	0 to 10000	<p>Remote PID I Integral Gain value for Remote System Temperature sensor control Modes. Refer to Local PID I for explanation.</p>
60	0 to 10000	<p>Remote PID D Derivative Gain value for Remote System Temperature sensor control Modes. Refer to Local PID D for explanation.</p>

Configuration & Tuning

Setup Menu (Continued)

No.	Range / Choices	Parameter and Description
61	0 to 10000	<p>Mixing Valve P Proportional Gain value for boiler Inlet temperature sensor control mode. A larger gain value results in tighter, more active, PID control. Gain is the primary PID modulation rate tuning adjustment and provides the immediate mixing valve modulation response.</p> <p>Pick a gain based on the desired initial response. The mixing valve can oscillate if the Proportional Gain is too large.</p>
62	0 to 10000	<p>Mixing Valve I Integral gain value for boiler inlet temperature sensor control mode. A smaller value makes the Integral ramp in less time (i.e., faster). Integral is a secondary PID modulation rate tuning adjustment that ramps the output over time (typically minutes).</p> <p>Based on the selected Mixing Valve P, select the corresponding (from table on previous page) Integral value. The mixing valve can oscillate if the Integral time is too small.</p>
63	0 to 10000	<p>Mixing Valve D The Derivative gain value for boiler inlet temperature sensor control mode. A larger Derivative gain value produces a larger PID output contribution proportional to the rate of change of the error (Setpoint – Boiler Inlet Temperature). When set equal to zero it has no effect on the output.</p>
64	0 to 10000	<p>Max Delta T P Proportional Gain value for boiler differential (boiler outlet minus inlet temperature sensor) temperature control mode. Refer to Local PID P for explanation.</p>
65	0 to 10000	<p>Max Delta T I Integral Gain value for boiler differential (boiler outlet minus inlet temperature sensor) temperature control mode. Refer to Local PID I for explanation.</p>
66	0 to 10000	<p>Max Delta T D Derivative Gain Term for boiler differential (boiler outlet minus inlet temperature sensor) temperature control mode. Refer to Local PID D for explanation.</p>

Configuration & Tuning

Manual Mode Menu

Manual mode allows the boiler modulation rate, boiler call for head output and mixing valve position to be directly positioned by the user. These are valuable tools for trouble shooting and setup.

No.	Range / Choices	Parameter and Description
101	Man Auto	Boiler Man/Auto Man: Remain in Manual Mode. Auto: Return to Boiler Mode specified by parameter/boiler conditions. Activated only when in Supervisor Mode.
102	0 to 100	Modulation Rate Sets the modulation rate to be used for boiler when in Manual Mode. Activated only when in Supervisor Mode and Boiler Man/Auto = Man.
103	On, Off	Boiler On/Off Sets the boiler start/stop status when in Manual Mode. No: Turn off boiler if running, otherwise remain off. Yes: Turn on boiler if off, otherwise remain on. Activated only when in Supervisor Mode and Boiler Man/Auto = Man.
104	Man Auto	Mixing Valve M/A Man: Remain in Manual Mode. Auto: Return to Control Mode specified by parameter/boiler conditions. Activated only when in Supervisor Mode.
105	0 to 100	Mixing Valve Sets the Mixing Valve % Open to be used for valve when in Manual Mode. Activated only when in Supervisor Mode and Mixing Valve M/A equals Man.

Trouble Shooting

Alarm Messages

Alarm Messages are shown one at a time in priority order. The message closest to the top of this List is displayed first. Following messages are not shown until the higher priority message has cleared. All alarm messages are also stored in the Fault History.

LCD Display Alarm Message	Recommended Action	Explanation
Low Water Level <i>Flashing Red Alarm Light</i> Off Switch	Manually Reset the Low Water Cutoff	Low Water Cutoff Switch When this option is configured and a control is installed, the manual reset low water safety relay is preventing the boiler from starting. If terminal (LC) does not receive power and the Call For Heat output (CH) is powered the "Low Water Level" Message is displayed.
	Turn Burner Switch On	Burner Switch is Off Control switch is in the OFF position and is preventing the boiler from starting. If terminal (OO) does not receive power and the Call For Heat output (CH) is powered the "OFF Switch" Message is displayed.
Low Water Flow <i>Red Alarm Light</i>	Ensure boiler pump is running and boiler water flow is unobstructed	Low Water Flow Switch Low water flow is preventing the boiler from starting. If terminal (WF) does not receive power and the Call For Heat output (CH) is powered the "Low Water Flow" Message is displayed.
Fuel Limit <i>Flashing Red Alarm Light</i>	Manually Reset the Fuel pressure switch	Low or High Gas Pressure Switch The low or high gas pressure switch is preventing the boiler from starting. If terminal (GP) does not receive power and the Call For Heat output (CH) is powered the "Fuel Limit" Message is displayed.
High Temp Limit <i>Flashing Red Alarm Light</i>	Manually Reset the High Temperature Aquastat	High Limit Temperature The high temperature limit (HL) (and operational temperature limit when provided) aquastat is preventing a boiler start. If terminal (HL) does not receive power and the Call For Heat output (CH) is powered the "High Temp Limit" Message is displayed.
Low Air Flow <i>Flashing Red Alarm Light</i>	Check combustion air blower and air pressure switch settings and wiring	Low Air Flow or Blocked Vent Switch Not Made The air flow (and blocked vent switch when provided) is preventing a boiler start. If terminal (CA) does not receive power and the Call For Heat output (CH) is powered the "Low Air Flow" Message is displayed.
FSG Fault <i>Flashing Red Alarm Light</i>	Manually Reset Required, Refer to Flame Safeguard Manual corrective actions	Flame Safeguard Fault The Flame Safeguard is preventing a boiler start. If terminal (AL) receives power at any time, the "Flame Failure" Message is displayed.
Outlet Temp Fail <i>Red Alarm Light</i>	Check wiring and sensor	Boiler Outlet Temperature Sensor Fail The boiler outlet temperature sensor is not connected or is reading above or below a valid range. When the boiler outlet sensor fails and the Outlet Sensor mode was selected the control will transfer to Lost Sensor Blind Mode.
Inlet Temp Fail <i>Red Alarm Light</i>	Check wiring and sensor	Boiler Inlet Temperature Sensor Fail The boiler inlet temperature sensor is not connected or is reading above or below a valid range. When the boiler inlet sensor fails the mixing valve output will drive to 0% and low temperature alarm and maximum water differential (boiler outlet minus boiler inlet) temperature hold are disabled.
OA Temp Fail <i>Red Alarm Light</i>	Check wiring and sensor	Outside Air Temperature Sensor Fail The outside air sensor is configured and is not connected or is reading above or below a valid range. When the outside air sensor fails the warm weather shutdown (WWSD) and outside air reset control logics are disabled.
Remote Temp Fail <i>Red Alarm Light</i>	Check wiring and sensor	Remote System Temperature Sensor Fail The remote system temperature sensor is configured and is not connected or is reading above or below a valid range. If Remote System Temperature Sensor mode was selected the control will transfer to Boiler Outlet Sensor Mode.

Trouble Shooting

Alarm Messages (continued)

LCD Display Alarm Message	Recommended Action	Explanation										
<p>Remote Input Fail</p> <p><i>Red Alarm Light</i></p>	<p>Check wiring and Remote System</p>	<p>Remote Control Input Fail The Remote Control Input is configured and is not connected or is above or below a valid range. When the remote control input fails the following control mode changes are taken automatically:</p> <table border="1" data-bbox="646 401 1498 552"> <thead> <tr> <th data-bbox="646 401 1068 428">Selected Modes</th> <th data-bbox="1068 401 1498 428">Resulting Control Mode</th> </tr> </thead> <tbody> <tr> <td data-bbox="646 428 1068 455">Remote Mod</td> <td data-bbox="1068 428 1498 455">Outlet sensor and Local Setpoint</td> </tr> <tr> <td data-bbox="646 455 1068 483">Remote Mod & Remote Sensor</td> <td data-bbox="1068 455 1498 483">Remote Sensor and Local Setpoint</td> </tr> <tr> <td data-bbox="646 483 1068 510">Remote SP</td> <td data-bbox="1068 483 1498 510">Outlet Sensor and Local Setpoint</td> </tr> <tr> <td data-bbox="646 510 1068 537">Remote SP & Remote Sensor</td> <td data-bbox="1068 510 1498 537">Remote Sensor and Local Setpoint</td> </tr> </tbody> </table>	Selected Modes	Resulting Control Mode	Remote Mod	Outlet sensor and Local Setpoint	Remote Mod & Remote Sensor	Remote Sensor and Local Setpoint	Remote SP	Outlet Sensor and Local Setpoint	Remote SP & Remote Sensor	Remote Sensor and Local Setpoint
Selected Modes	Resulting Control Mode											
Remote Mod	Outlet sensor and Local Setpoint											
Remote Mod & Remote Sensor	Remote Sensor and Local Setpoint											
Remote SP	Outlet Sensor and Local Setpoint											
Remote SP & Remote Sensor	Remote Sensor and Local Setpoint											
<p>Comm Failure</p> <p><i>Red Alarm Light</i></p>	<p>Check wiring and Remote System</p> <p>Confirm each boiler has a unique address</p>	<p>Communication Failure The Modbus or Peer-To-Peer network has failed. When the Modbus network fails the following control mode changes are taken automatically:</p> <table border="1" data-bbox="646 737 1498 888"> <thead> <tr> <th data-bbox="646 737 1068 764">Selected Modes</th> <th data-bbox="1068 737 1498 764">Resulting Control Mode</th> </tr> </thead> <tbody> <tr> <td data-bbox="646 764 1068 791">Modbus Mod</td> <td data-bbox="1068 764 1498 791">Outlet sensor and Local Setpoint</td> </tr> <tr> <td data-bbox="646 791 1068 819">Modbus Mod & Remote Sensor</td> <td data-bbox="1068 791 1498 819">Remote Sensor and Local Setpoint</td> </tr> <tr> <td data-bbox="646 819 1068 846">Modbus SP</td> <td data-bbox="1068 819 1498 846">Outlet Sensor and Local Setpoint</td> </tr> <tr> <td data-bbox="646 846 1068 873">Modbus SP & Remote Sensor</td> <td data-bbox="1068 846 1498 873">Remote Sensor and Local Setpoint</td> </tr> </tbody> </table> <p>After a Modbus communication failure, the 'Comm Failure' alarm is not cleared until communication is restored and a successful writes to both the Remote On / Off Modbus Command (00004) and Remote Firing Rate or Remote Setpoint (40006) points have been completed, power is cycled or the protocol parameter is changed to Peer-To-Peer and then back to Modbus.</p> <p>When a Peer-To-Peer network has failed the boilers begin operation as stand alone boilers using the selected parameters.</p> <p>After a Peer-To-Peer communication failure the 'Comm Failure' alarm is not cleared until communication is restored and the boiler rejoins a network with at least one other boiler, power is cycled or the protocol parameter is changed to Modbus and then back to Peer-To-Peer.</p>	Selected Modes	Resulting Control Mode	Modbus Mod	Outlet sensor and Local Setpoint	Modbus Mod & Remote Sensor	Remote Sensor and Local Setpoint	Modbus SP	Outlet Sensor and Local Setpoint	Modbus SP & Remote Sensor	Remote Sensor and Local Setpoint
Selected Modes	Resulting Control Mode											
Modbus Mod	Outlet sensor and Local Setpoint											
Modbus Mod & Remote Sensor	Remote Sensor and Local Setpoint											
Modbus SP	Outlet Sensor and Local Setpoint											
Modbus SP & Remote Sensor	Remote Sensor and Local Setpoint											
<p>Low Inlet Temp</p> <p><i>Red Alarm Light</i></p>	<p>Check wiring and sensor</p> <p>Check return water temperature. Consider system or operational changes to avoid low temperature events</p>	<p>Low Boiler Inlet Temperature If the boiler inlet temperature is below the Low boiler inlet temperature setpoint, the "Low Inlet Temp" Message is displayed and the boiler inlet temperature history is stored. See following page for additional information on Low boiler inlet temperature history storage and retrieval.</p>										
<p>Memory Failure</p> <p><i>Red Alarm Light</i></p>	<p>Call Factory; Reset all memories in System menu: Clr BIT History Clr Alarm Hist Clr Run Time Cnt Clr Cycle Cnt Factory Defaults</p> <p>(Factory Level Password is required)</p>	<p>Memory Failure New software has been installed in the TSBC or a power interruption has caused a memory failure. The Call For Heat will be prevented until the condition is cleared.</p>										

Trouble Shooting

Diagnostic Menu

All values shown in Diagnostic Menu are for display only and cannot be adjusted by the operator. Press and hold the  key to leave the Display Mode and access the Main Menu.

Use the   keys scroll down to the Diagnostic Menu and push the  key.

Boiler Inlet Temperature History

Display	Description
<div style="border: 1px solid black; padding: 5px; margin-bottom: 5px;">13:31 09/10/06 BOT Sensor Fail</div>	<p>FAULT HISTORY The last 10 alarms are stored in memory. Use the arrow keys to scroll through the alarms. Each alarm is displayed with the time and date it occurred.</p>
<div style="border: 1px solid black; padding: 5px; margin-bottom: 5px;">8:45 09/10/06 Low Temp: 130F</div> <div style="border: 1px solid black; padding: 5px;">8:45 09/10/06 Low for 1:00:02</div>	<p>BIT HISTORY The last 10 Low Inlet Temperature Events are stored in memory. Each time the boiler inlet temperature is less than the "Min In H2O Temp." parameter, a low temperature event is recorded. The BIT History screen automatically toggles between the "lowest temperature for the event" and "Duration Below Setpoint" displays and provides time and date of each event.</p>
	<p>SYSTEM Items provided by this menu are shown on page 40.</p>
<div style="display: flex; flex-direction: column; align-items: center;"> <div style="border: 1px solid black; padding: 5px; margin-bottom: 5px;">DHW Priority Off</div> <div style="border: 1px solid black; padding: 5px; margin-bottom: 5px;">Local/Remote Off</div> <div style="border: 1px solid black; padding: 5px; margin-bottom: 5px;">Remote On/Off Off</div> <div style="border: 1px solid black; padding: 5px; margin-bottom: 5px;">Spare Input Off</div> <div style="border: 1px solid black; padding: 5px; margin-bottom: 5px;">Low Water Cutoff Off</div> <div style="border: 1px solid black; padding: 5px; margin-bottom: 5px;">Burner On / Off Off</div> <div style="border: 1px solid black; padding: 5px; margin-bottom: 5px;">Low Water Flow Off</div> <div style="border: 1px solid black; padding: 5px; margin-bottom: 5px;">Fuel Limit Off</div> <div style="border: 1px solid black; padding: 5px; margin-bottom: 5px;">Oper./High Limit Off</div> <div style="border: 1px solid black; padding: 5px; margin-bottom: 5px;">Low Air Flow Off</div> <div style="border: 1px solid black; padding: 5px; margin-bottom: 5px;">Fuel Energized Off</div> <div style="border: 1px solid black; padding: 5px;">FSG Alarm Off</div> </div>	<p>DISCRETE INPUTS These screens provide a convenient way to trouble shoot wiring during the installation phase. Each screen provides the status of a controller input.</p> <p>These displays show the status of the corresponding Discrete Input.</p> <p style="text-align: center;">PLEASE NOTE</p> <p>These displays provide limit string monitoring status. These inputs are only monitored when there is a Call For Heat. Additionally, if one of these items is 'open', items down stream are not monitored.</p> <p>These displays show the status of the corresponding Discrete Input.</p>

Trouble Shooting

Diagnostic Menu (Continued)

Display	Description
<div style="border: 1px solid black; padding: 5px; margin-bottom: 5px;">Call For Heat Off</div> <div style="border: 1px solid black; padding: 5px; margin-bottom: 5px;">Lockout Indicator Off</div> <div style="border: 1px solid black; padding: 5px; margin-bottom: 5px;">Vent Inducer Off</div> <div style="border: 1px solid black; padding: 5px; margin-bottom: 5px;">Boiler Pump Off</div> <div style="border: 1px solid black; padding: 5px; margin-bottom: 5px;">System Pump Off</div> <div style="border: 1px solid black; padding: 5px;">Spare Output Off</div>	<p>DISCRETE OUTPUTS</p> <p>These screens provide a convenient way to trouble shoot wiring during the installation phase. Each screen provides the status of a controller output.</p> <p>These displays show the status of the corresponding Discrete Output.</p>
<div style="border: 1px solid black; padding: 5px; margin-bottom: 5px;">Boiler Outlet 0%</div> <div style="border: 1px solid black; padding: 5px; margin-bottom: 5px;">Boiler Inlet 0%</div> <div style="border: 1px solid black; padding: 5px; margin-bottom: 5px;">Outside Air 0%</div> <div style="border: 1px solid black; padding: 5px; margin-bottom: 5px;">Remote System 0%</div> <div style="border: 1px solid black; padding: 5px; margin-bottom: 5px;">Remote Input 0%</div> <div style="border: 1px solid black; padding: 5px;">PCB Temperature 0%</div>	<p>ANALOG INPUTS</p> <p>These screens provide a convenient way to trouble shoot wiring during the installation phase. Each screen provides the status of a controller analog input.</p> <p>These displays show the status of the corresponding Analog Input.</p>
<div style="border: 1px solid black; padding: 5px; margin-bottom: 5px;">Boiler Demand 0%</div> <div style="border: 1px solid black; padding: 5px;">Mix Valve Demand 0%</div>	<p>ANALOG OUTPUTS</p> <p>These screens provide a convenient way to trouble shoot wiring during the installation phase. Each screen provides the status of a controller analog Output.</p> <p>These displays show the status of the corresponding Analog Output.</p>

Trouble Shooting

Diagnostic Menu (Continued)

System Menu

Display	Description
Software Rev. S 3.24	Software Revision Displays current Software Revision.
PCB Temperature 70 F	PCB Board Temperature The operating range for the control is 32 to 140 F.
Clr BIT Hist No Action	Clear Boiler Inlet Temperature (BIT) Memory No Action History remains unchanged. Yes Clears low BIT memory.
Clr Alarm Hist No Action	Clear Alarm History Memory No Action History Remains unchanged. Yes Clears alarms memory.
Clr Run Time Cnt No Action	Clear Boiler Run Time Hour Accumulator Memory Boiler Run Time Hours are displayed in Display Mode as "Hours". No Action Hours Remain unchanged. Yes Clears accumulated hours memory.
Clr Cycle Cnt No Action	Clear Boiler Start/Stop Cycle Accumulator Memory Boiler Start/Stop cycles are displayed in Display Mode as "Cycles". No Action Hours Remain unchanged. Yes Clears accumulated cycles memory.
Factory Defaults No Action	Clear User Installed Parameter Memory No Action Currently set parameter values are unchanged. Set Sets all parameters back to their Factory Default values.
Actual RST 32 F Actual OAT -40 F Actual BOT 32 F Actual BIT 32 F	Temperature Input Fine Calibration All inputs are factory calibrated. However, it may become necessary to field calibrate due to measuring errors resulting from long wire lengths or third party sensor use. This is a single point calibration tool. To gain the greatest benefit, it is recommended to calibrate as close as possible to the expected operating temperature and measure the temperature at the sensor location. Remote System Temperature (RST) Outside Air Temperature (OAT) Boiler Outlet Temperature (BOT) Boiler Inlet Temperature (BIT) Calibration Procedure: <ol style="list-style-type: none"> 1. Select sensor that requires field calibration. 2. Run boiler to rated condition. 3. Enter the Actual RST, OAT, BOT and BIT. 4. Display will flash back to the default (Note: Calibration number does not remain on screen). 5. Calibration is complete. A one point calibration offset is calculated and applied.
Param Code	Parameter Code This number represents "Network Relevant" parameters. It can be used to ensure that these parameters are identical when establishing a Peer-To-Peer network.

Trouble Shooting

Sensor Temperature vs. Resistance

Water Temperature		Ohms of	Water Temperature		Ohms of	Water Temperature		Ohms of
°C	°F	Resistance	°C	°F	Resistance	°C	°F	Resistance
-22	-8	110,460	14	58	16,126	51	124	3,453
-21	-6	103,486	16	60	15,313	52	126	3,311
-20	-4	96,999	17	62	14,546	53	128	3,176
-19	-2	90,962	18	64	13,822	73	164	1,565
-18	0	85,340	19	66	13,139	74	166	1,508
-17	2	80,103	20	68	12,493	76	168	1,453
-16	4	75,222	21	70	11,884	77	170	1,401
-14	6	70,670	22	72	11,307	78	172	1,350
-13	8	66,424	23	74	10,762	79	174	1,302
-12	10	62,460	24	76	10,247	80	176	1,256
-11	12	58,759	26	78	9,760	81	178	1,212
-10	14	55,301	27	80	9,298	82	180	1,169
-9	16	52,069	28	82	8,862	83	182	1,129
-8	18	49,047	29	84	8,448	84	184	1,089
-7	20	46,220	30	86	8,056	86	186	1,052
-6	22	43,574	31	88	7,685	87	188	1,016
-4	24	41,097	32	90	7,333	88	190	981.2
-3	26	38,776	33	92	6,999	89	192	947.9
-2	28	36,601	34	94	6,682	90	194	915.9
-1	30	34,562	36	96	6,382	91	196	885.2
0	32	32,650	37	98	6,097	92	198	855.7
1	34	30,856	38	100	5,826	93	200	827.3
2	36	29,171	39	102	5,569	94	202	800.1
3	38	27,590	40	104	5,325	96	204	773.8
4	40	26,104	41	106	5,093	97	206	748.6
6	42	24,707	42	108	4,872	98	208	724.3
7	44	23,394	43	110	4,663	99	210	700.9
8	46	22,159	44	112	4,463	100	212	678.4
9	48	20,997	46	114	4,273	101	214	656.8
10	50	19,903	47	116	4,093	102	216	635.9
11	52	18,873	48	118	3,921	103	218	615.8
12	54	17,902	49	120	3,757	104	220	596.5
13	56	16,988	50	122	3,601			

Trouble Shooting

Security Menu

Passwords

There are three Access Levels in the system; Basic, Supervisor, and Factory.

- At the **BASIC** Access Level, the user can view many parameters, but is only allowed to edit a small sub-set of the parameters that are visible.
- At the **SUPERVISOR** Access Level, the user can view and edit most parameters that are visible. Note: not all parameters will be visible at the Supervisor Access Level.
- At the **FACTORY** Access Level, all relevant internal parameters in the system will be visible and programmable.

The Basic Access Level is the access level at power-up if the system password parameter is not equal to zero. The Supervisor Access Level is the access level at power-up if the system password parameter is equal to zero. If the system password is non-zero, the Supervisor Access Level may be reached by entering the correct password in the Enter Password parameter.

The Factory Access Level can be reached by entering the factory password in the Enter Password parameter and holding the Enter key for at least two seconds when accepting the value entered. The display will jump to the Access Level parameter menu when the system has entered the Factory Access Level. Note that the Access Level parameters value will indicate "Supervisor".

To exit either of the privileged access levels (Factory and Supervisor), change the value of the Access Level parameter from "Supervisor" to "Basic". Also, if no key is pressed for ~ 1 hour, the access level will automatically revert to Basic.

Range / Choices	Parameter and Description
Basic Supervisor	Access Level Basic: Select Basic Level Access to parameters/variables. Supervisor: Select Password Level Access to parameters/variables.
0 to 9999	Enter Password Allows user to enter password to gain access to both Supervisor Access and Factory Access Levels.
0 to 9999	Set Password Holds the user-defined password for the boiler. A password = 0 means no password protection. Access Level will default to Supervisor Level at power-up.

Specifications

General

Mechanical:

Panel Assembly: 8 inches wide x 6 inches tall
 Message Display: 2 x 16 Character, 8.06 mm characters

Environmental:

Operating Temp: 32 to 140 F (0 to 60 C)
 Storage Temp: -20 to 150 F (-28 to 65 C)
 Humidity Limits: 15 to 95% (non-condensing)
 Front Panel: NEMA 1

Electrical:

Power Supply: 24Vac
 Note: All 24Vac Inputs must be connected to the same phase as (PR)
 Internal Power Consumption: 8 VA max, 24 Vac (+/- 15%), and 6 VA max,
 12 Vdc 0.5A for LO, VI, BP, SP and SO

Discrete Inputs:

Terminal	Description	Rating
DP	Domestic Hot Water Priority (DHWP)	12 Vdc / 1 mA
LR	Local / Remote	12 Vdc / 1 mA
RO	Remote On / Off (Enable)	12 Vdc / 1 mA
SI	Spare Input (Programmable)	12 Vdc / 1 mA
LC	Low Water Cutoff Switch	24 Vac / 1mA
OO	Burner On / Off Switch	24 Vac / 1mA
WF	Low Water Flow	24 Vac / 1mA
GP	High and Low Gas Pressure Switches	24 Vac / 1mA
HL	Operating or High Limit	24 Vac / 1mA
CA	Low Combustion Air Flow	24 Vac / 1mA
CS	Fuel Valve Energized	24 Vac / 1mA
AL	Flame Safeguard Alarm	24 Vac / 1mA

Discrete Outputs:

Terminal	Description	Rating
CH	Call For Heat (CFH)	24 Vac / 10A
LO	Lockout Indicator	12 Vdc / 100mA
VI	Spare Output	12 Vdc / 100mA
BP	Boiler Pump	12 Vdc / 100mA
SP	System Pump	12 Vdc / 100mA
SO	Spare Output (Programmable)	12 Vdc / 100mA

Analog Inputs:

Terminal	Description	Rating
BO	Boiler Outlet Water Temperature	10k Thermister, 5Vdc, 5 mA max load
BI	Boiler Inlet Water Temperature	10k Thermister, 5Vdc, 5 mA max load
O+ O-	Outside Air Temperature	10k Thermister, 5Vdc, 5 mA max load
R+ R-	Remote System Temperature	10k Thermister, 5Vdc, 5 mA max load
C+ C-	Remote Modulation Rate or Remote Setpoint	0-10 Vdc (~100K ohm impedance) 1Vdc = 0%, 9Vdc = 100%

Analog Outputs:

Terminal	Description	Rating
P+ P-	Modulation Rate Output to Mod Motor	0 – 100 % Duty Cycle, 0V – Off, ~10V - On
V+ V-		0 – 10 V, 5 mA max
MS MR	Mixing Valve Output	4-20mA 4 mA = 0 % Open, 20 mA = 100% Open

Appendix A Parameter Summary

Network Relevant*	Parameter	Range / Choices	Security Level**	Page
-------------------	-----------	-----------------	------------------	------

Boiler Configuration Menu

Update	Display Units	Deg F / Deg C	Basic	28
Yes	Boiler Pump	None / On Always / Purge / On Lead	Supervisor	28
Update	If Purge, set Pump Prepurge	0 to 600 seconds	Supervisor	28
Update	Postpurge Delta	0 to 20 F	Supervisor	28
-	Inlet Sensor	Yes / No	Supervisor	28
-	Mixing Valve	Yes / No	Supervisor	28
Update	Set Time/Date	hour : minute month / day / year	Basic	28
Update	Fuel Limit	Yes / No	Factory	28
Update	Spare Input	Off / Sys Pump Feedback / Low Fire	Supervisor	28
Update	Spare Output	Off / CAD / Sys Pump BU / Soft Alarm	Supervisor	28

System Configuration Menu

Yes	DHWP	Off / Isolated Demand / Shared Demand	Basic	29
Yes	Remote control	No / Remote SP / Modbus SP / Remote Mod / Modbus Mod	Supervisor	29
-	Remote 1 volts =	60 F to 150 F	Supervisor	29
-	Remote 9 volts =	150 F to 230 F	Supervisor	29
Yes	Remote Sensor	No / Display Only / Control	Supervisor	29
Yes	System Pump	Yes / No	Supervisor	29
Update	LWC or CAD	Yes / No	Supervisor	29
Update	Alarm Message	Low Water level	Supervisor	29

Setup Menu

Yes	WWSD	Off / WWSD of Boiler / WWSD of Sys Pump / Both	Basic	30
Yes	LL Start Trigger	50 to 100% of Modulation Rate	Supervisor	30
Yes	LL Stop Trigger	0 to 50% of Modulation Rate	Supervisor	30
Yes	Boiler On Delay	0 to 900 seconds	Supervisor	30
Yes	Boiler Off Delay	0 to 900 seconds	Supervisor	30
Yes	%FR On Delay	1 to 30 minutes	Factory	30
Yes	%FR Off Delay	1 to 30 minutes	Factory	30
Yes	High Fire Limit	40 - 100 % Modulation Rate	Supervisor	30
Yes	Deg/Min Hold Off	1 - 10 Degrees / Minute	Factory	30
Yes	Cutback Setpoint	100 F - 240 F	Factory	30
Yes	Net Start Dwell	16 to 420 Seconds	Factory	31
Yes	Limit Fault Time	3 to 120 Seconds	Factory	31
Yes	Rotation	Enable / Disable	Basic	31
Yes	Rotation After	8 to 720 hours	Basic	31
Yes	Outdoor Sensor	No / Display Only / Outdoor Reset	Basic	32
Yes	Outdoor Set Up	40 F to 100 F	Basic	32
Yes	Boiler Set Up	80 F to 180 F	Basic	32
Yes	Outdoor Design	- 20 F to 50F	Basic	32
Yes	Boiler Design	80 F to 220 F	Basic	32

* Parameters identified by "Yes" under the "Network Relevant" column must be configured identically on all boilers. **Unexpected boiler behavior may result if these parameter values differ among boilers on the network.** Once communication is established between all boilers in a system, changes to parameters identified as "Yes" or "Update" under the "Network Relevant" column at the keypad of any boiler will update that parameter in all boilers.

** To change your current security level, refer to page 42 Security Level operations.

Appendix A Parameter Summary (continued)

Network Relevant*	Parameter	Range/Choices	Security Level**	Page
-------------------	-----------	---------------	------------------	------

Setup Menu (continued)

-	Blower Spd High	0 to100 % of full scale	Factory	31
-	Blower Spd Low	0 to100 % of full scale	Factory	31
-	Low Fire Spd	0 to100 % Modulation Rate	Factory	31
-	Fan Purge Spd	0 to100 % Modulation Rate	Factory	31
Yes	Low Fire Hold	0 to 1200 sec	Factory	31
Yes	Post Purge Time	0 to 600 sec	Factory	31
Yes	Local PID P	0-10000	Supervisor	33
Yes	Local PID I	0-10000	Supervisor	33
Yes	Local PID D	0-10000	Supervisor	33
Yes	Remote PID P	0-10000	Supervisor	33
Yes	Remote PID I	0-10000	Supervisor	33
Yes	Remote PID D	0-10000	Supervisor	33
Yes	Mixing Valve P	0-10000	Supervisor	34
Yes	Mixing Valve I	0-10000	Supervisor	34
Yes	Mixing Valve D	0-10000	Supervisor	34
Yes	Max Delta T P	0-10000	Supervisor	34
Yes	Max Delta T I	0-10000	Supervisor	34
Yes	Max Delta T D	0-10000	Supervisor	34

Setpoint Menu

Yes	Operational Setpoint	60 F to 230 F	Basic	19
Yes	On point	0 F to – 99 F	Basic	19
Yes	Off Point	0 F to 99 F	Basic	19
Yes	High Temp Stop	60 F to 230 F	Basic	19
Yes	DHWP setpoint	140 F to 230 F	Basic	19
Yes	WWSD setpoint	40 F 90 F	Basic	19
Yes	Max SP	140 F to 230 F	Supervisor	19
Yes	Min SP	60 F to 230 F	Supervisor	19
Yes	Min BIT	110 F to 235 F	Factory	19
Update	Min Inlet H2O Temp	110 F to 180 F	Supervisor	19
Update	Max H2O Delta T	20F to 50 F	Supervisor	19
Update	Max Delta T Hold	20F to 50 F	Supervisor	19

Communication Menu

-	Protocol	Peer to Peer / Modbus	Supervisor	24
-	Modbus Address	1-247	Supervisor	24
-	Baud Rate	9.6 / 19.2 / 38.4	Supervisor	24
-	Parity	Odd / Even / None	Supervisor	24
-	Timeout	1 Second to 120 Seconds	Supervisor	24
-	Boiler Address	1 to 8	Supervisor	24

* Parameters identified by “Yes” under the “Network Relevant” column must be configured identically on all boilers. **Unexpected boiler behavior may result if these parameter values differ among boilers on the network.** Once communications is established between all boilers in a system, changes to parameters identified as “Yes” or “Update” under the “Network Relevant” column at the keypad of any boiler will update that parameter in all boilers.

** To change your current security level, refer to page 42 Security Level operations.

Appendix B Supervisor Parameter Worksheet

Parameter	Range / Choices	Units
-----------	-----------------	-------

Boiler Configuration Menu

Display Units	Circle one: Deg F Deg C	
Boiler Pump	Circle one: None On Always Purge On Lead	
Pump Prepurge		Seconds
Postpurge Delta		F
Inlet Sensor	Circle one: Yes No	
Mixing Valve	Circle one: Yes No	
Spare Input	Circle one: Off Low Fire Sys Pump Feedback	
Spare Output	Circle one: Off CAD Soft Alarm Sys Pump BU	

System Configuration Menu

DHWP	Circle one: Off Isolated Demand Shared Demand	
Remote control	Circle one: No Remote SP Modbus SP Remote Mod Modbus Mod	
Remote 1 volts =		F
Remote 9 volts =		F
Remote Sensor	Circle one: No Display Only Control	
System Pump	Circle one: Yes No	
LWC or CAD	Circle one: Yes No	
Alarm Message		

Setup Menu

WWSD	Circle one: Off WWSD of Boiler WWSD of Sys Pump Both	
LL Start Trigger		%
LL Stop Trigger		%
Boiler On Delay		Seconds
Boiler Off Delay		Seconds
High Fire Limit		%
Rotation	Circle one: Enable Disable	
Rotation After		Hours
Outdoor Sensor	Circle one: No Display Only Outdoor Reset	
Outdoor Set Up		F
Boiler Set Up		F
Outdoor Design		F
Boiler Design		F
Local PID P		
Local PID I		
Local PID D		
Remote PID P		
Remote PID I		
Remote PID D		
Mixing Valve P		
Mixing Valve I		
Mixing Valve D		
Max Delta T P		
Max Delta T I		
Max Delta T D		

Appendix B Supervisor Parameter Worksheet (continued)

Parameter	Range / Choices	Units
Setpoint Menu		
Operational Setpoint		F
On point		F
Off Point		F
High Temp Stop		F
DHWP setpoint		F
WWSD setpoint		F
Max SP		F
Min SP		F
Min Inlet H2O Temp		F
Max H2O Delta T		F
Max Delta T Hold		F
Communication Menu		
Protocol	Circle one: Peer to Peer Modbus	
Modbus Address		
Baud Rate	Circle one: 9.6 19.2 38.4	
Parity	Circle one: Odd Even None	
Timeout		Seconds
Boiler Address		